



**DANGER**

**Danger of electrical shock, burns or death.** Always remove all power sources before attempting any repair, service or diagnostic work. Power can be present from shore power, generator, inverter or battery. All power sources must be disabled and secured before performing any service.



**CAUTION**

If you lack the skills, tools or equipment to perform diagnostic or repair work leave such work to an authorized Winnebago Industries dealer or other qualified shop.

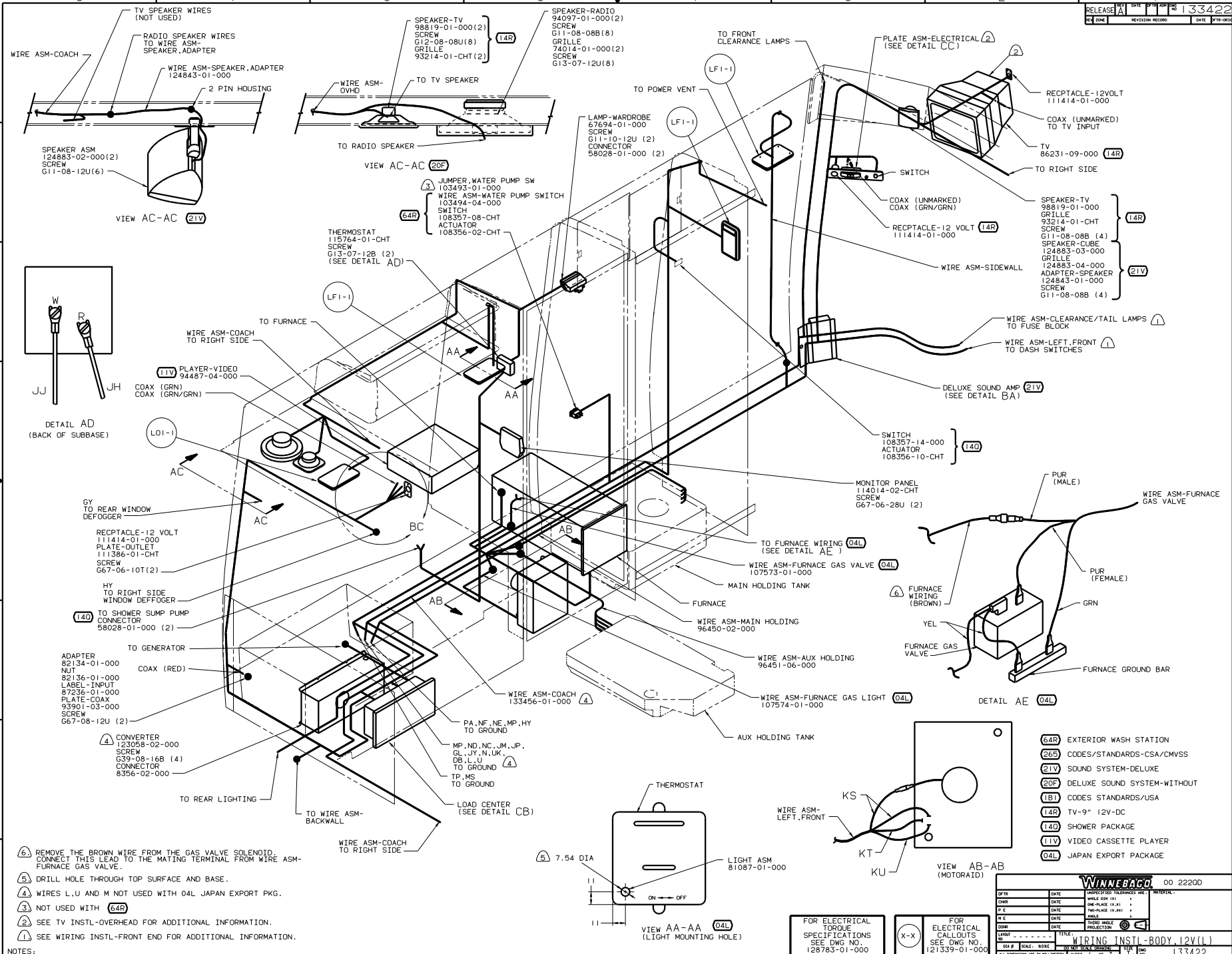

NOTES:  
 6. REMOVE THE BROWN WIRE FROM THE GAS VALVE SOLENOID. CONNECT THIS LEAD TO THE MATING TERMINAL FROM WIRE ASM-FURNACE GAS VALVE.  
 5. DRILL HOLE THROUGH TOP SURFACE AND BASE.  
 4. WIRES L,U AND M NOT USED WITH 04L JAPAN EXPORT PKG.  
 3. NOT USED WITH 64R  
 2. SEE TV INSTL-OVERHEAD FOR ADDITIONAL INFORMATION.  
 1. SEE WIRING INSTL-FRONT END FOR ADDITIONAL INFORMATION.

FOR ELECTRICAL SPECIFICATIONS SEE DWG NO. 128763-01-000

X-X FOR ELECTRICAL CALLOUTS SEE DWG NO. 121339-01-000

QTY	DATE	UNSPECIFIED DIMENSIONS ARE IN INCHES	MATERIAL
CHP	DATE	ONE-PLACE (19.81)	
PIE	DATE	TWO-PLACE (19.81)	
P/E	DATE	MISC.	
CON	DATE	INDU. WASTE PRODUCER	

WINNEBAGO 00 22200

WIRING INSTL-BODY, 12V(L)

REF: 130479-N

133422

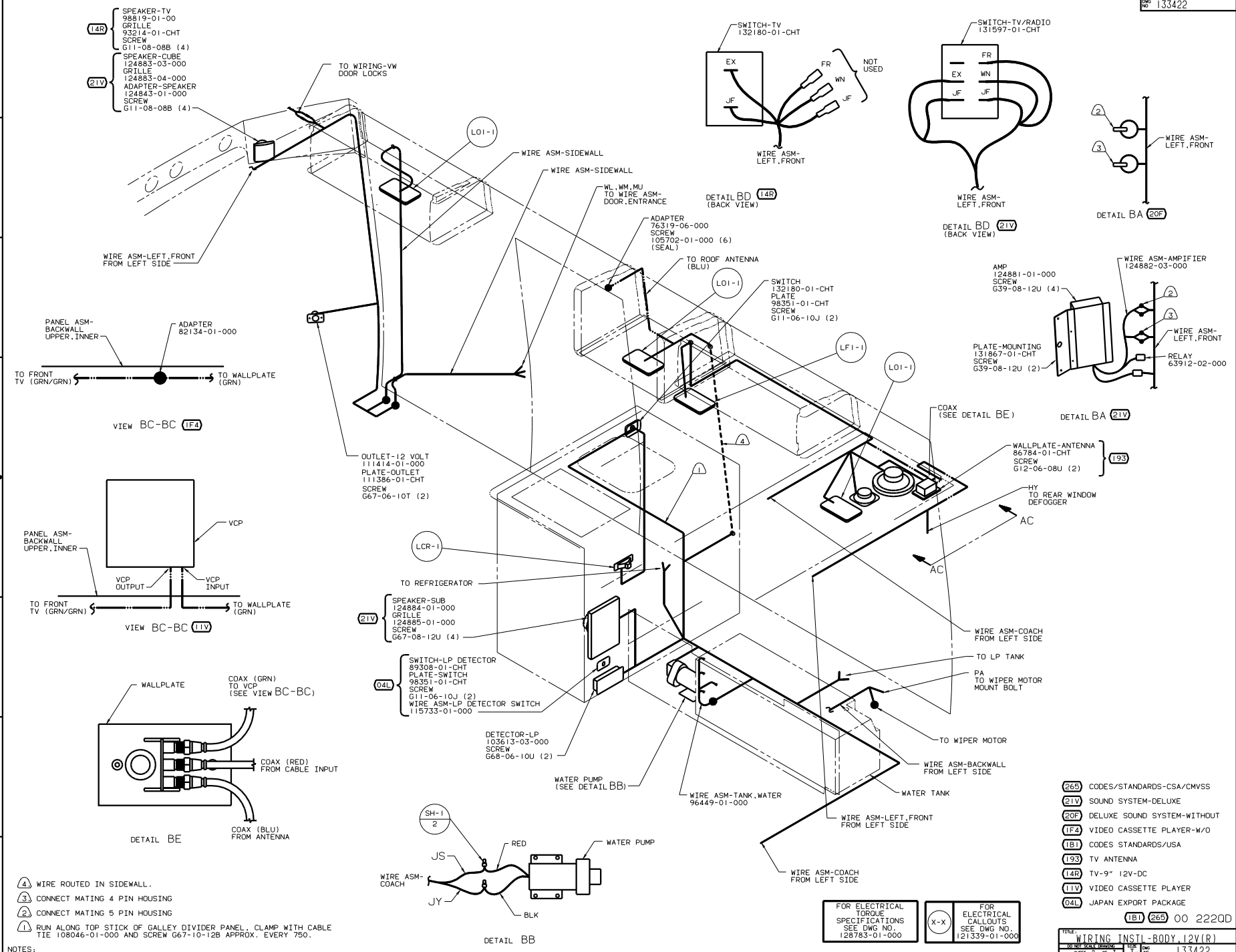

- 8 { 14R } SPEAKER-TV 98819-01-00  
GRILLE 93214-01-CHT  
SCREW G11-08-08B (4)
- 21V { 21V } SPEAKER-CUBE 124883-03-000  
GRILLE 124883-04-000  
ADAPTER-SPEAKER 124843-01-000  
SCREW G11-08-08B (4)

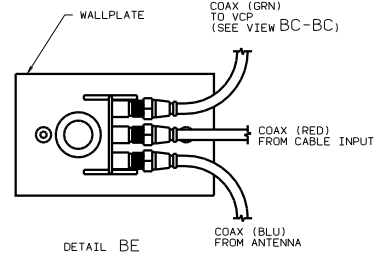
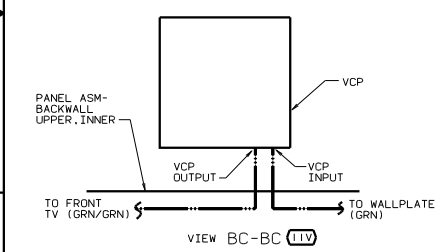
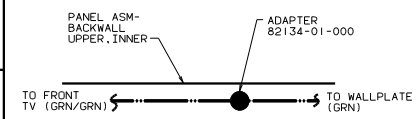
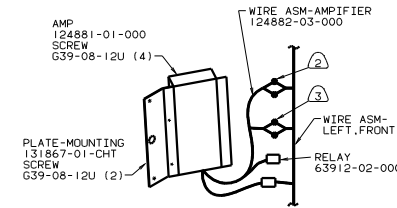
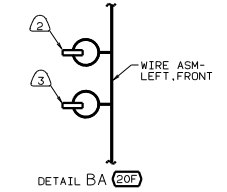
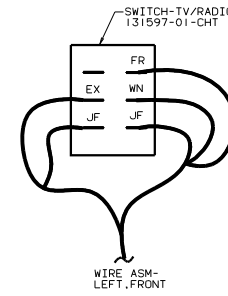
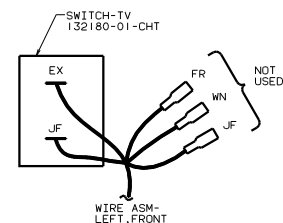

- 21V { 21V } SPEAKER-SUB 124884-01-000  
GRILLE 124885-01-000  
SCREW G67-08-12U (4)
- 04L { 04L } SWITCH-LP DETECTOR 89308-01-CHT  
PLATE-SWITCH 98351-01-CHT  
SCREW G11-06-10J (2)  
WIRE ASM-LP DETECTOR SWITCH 15733-01-000

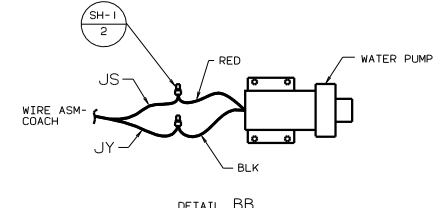

- 265 CODES/STANDARDS-CSA/CMVSS
- 21V SOUND SYSTEM-DELUXE
- 20F DELUXE SOUND SYSTEM-WITHOUT
- 1F4 VIDEO CASSETTE PLAYER-W/O
- 1B1 CODES STANDARDS/USA
- 193 TV ANTENNA
- 14R TV-9" 12V-DC
- 11V VIDEO CASSETTE PLAYER
- 04L JAPAN EXPORT PACKAGE

FOR ELECTRICAL TORQUE SPECIFICATIONS SEE DWG NO. 128783-01-000

X-X FOR ELECTRICAL CALLOUTS SEE DWG NO. 121339-01-000

- 4 WIRE ROUTED IN SIDEWALL.
- 3 CONNECT MATING 4 PIN HOUSING
- 2 CONNECT MATING 5 PIN HOUSING
- 1 RUN ALONG TOP STICK OF GALLEY DIVIDER PANEL. CLAMP WITH CABLE TIE 108046-01-000 AND SCREW G67-10-12B APPROX. EVERY 750.

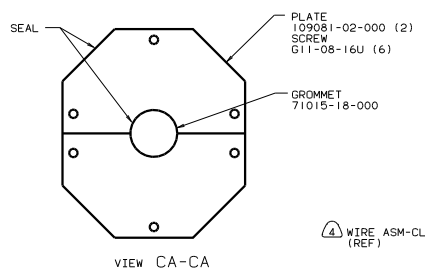

- ② ③ LAMP-CLEARANCE, RED 111102-01-000 (5)  
LAMP-MARKER, LENS, RED 111102-03-000 (5)  
SCREW G39-08-12U (EXT) (10)
- ⑤ LAMP ASM-CENTER BRAKE 121950-01-000  
SCREW (SUPPLIED W/LAMP)
- ④ LAMP-CLEARANCE, RED 111102-01-000 (5)  
LAMP-MARKER, LENS, RED 111102-03-000 (5)  
SCREW G39-08-12U (EXT) (10)
- ⑤ LAMP ASM-CENTER BRAKE 121950-01-000  
SCREW (SUPPLIED W/LAMP)
- ④ WIRE ASM-BACKWALL 130558-01-000  
130558-02-000

- ④ WIRE ASM-CLEARANCE/TAILLAMPS (REF)
- ④ WIRE ASM-LEFT, FRONT
- ④ WIRE ASM-CLEARANCE/TAILLAMPS (REF)
- ④ WIRE ASM-LEFT, FRONT
- ④ WIRE ASM-CLEARANCE/TAILLAMPS (REF)
- ④ WIRE ASM-LEFT, FRONT
- ④ WIRE ASM-CLEARANCE/TAILLAMPS (REF)
- ④ WIRE ASM-LEFT, FRONT
- ④ WIRE ASM-CLEARANCE/TAILLAMPS (REF)
- ④ WIRE ASM-LEFT, FRONT

- ④ WIRE ASM-CLEARANCE/TAILLAMPS (REF)
- ④ WIRE ASM-LEFT, FRONT
- ④ WIRE ASM-CLEARANCE/TAILLAMPS (REF)
- ④ WIRE ASM-LEFT, FRONT
- ④ WIRE ASM-CLEARANCE/TAILLAMPS (REF)
- ④ WIRE ASM-LEFT, FRONT
- ④ WIRE ASM-CLEARANCE/TAILLAMPS (REF)
- ④ WIRE ASM-LEFT, FRONT
- ④ WIRE ASM-CLEARANCE/TAILLAMPS (REF)
- ④ WIRE ASM-LEFT, FRONT

- ⑥ ON INTERIOR OF CAP, GRIND OFF TIP OF SCREW PRIOR TO SEALING (TO PROVIDE INNER LINER CLEARANCE).
  - ⑤ NOT USED WITH 04L
  - ④ SEE WIRING INSTL-FRONT END FOR ADDITIONAL INFORMATION.
  - ③ DELETE ALL CLEARANCE LAMPS WITH 04L
  - ② LOCATE ON CENTER OF HOLE IN CAP ASM-REAR.
1. CONNECTOR-PLUG, TRAILER 113589-01-000 TO BE SUPPLIED LOOSE IN COACH WITH TRAILER TOW PACKAGE.

FOR ELECTRICAL TORQUE SPECIFICATIONS SEE DWG NO. 128783-01-000

NOTES:

ANT-1

- LAMP-CLEARANCE, AMBER 113709-01-000 (5)  
SCREW G11-08-12T (10)

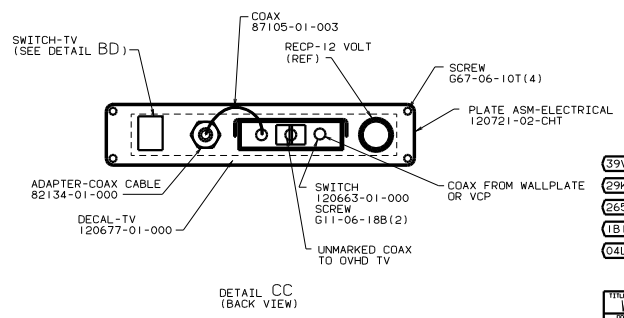
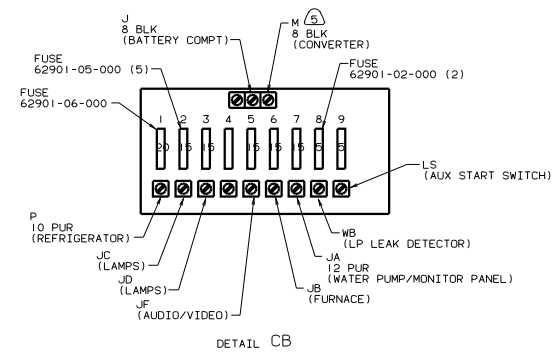
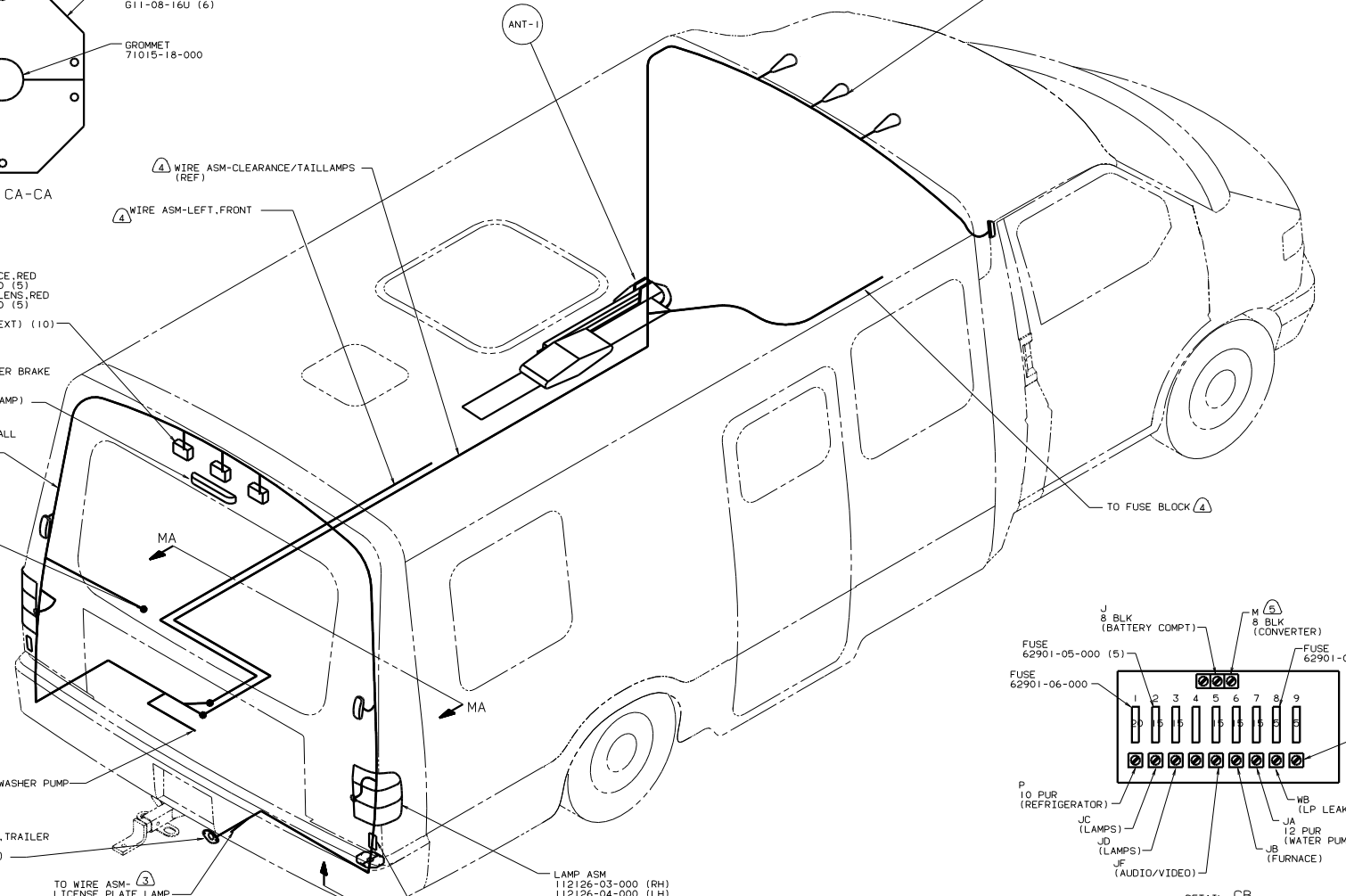

- LAMP ASM 112126-03-000 (RH)  
112126-04-000 (LH)  
SOCKET-LAMP 112709-01-000 (2)  
112709-02-000 (2)  
112709-03-000 (2)  
BULB 112707-01-000 (4)  
112708-01-000 (2)  
BRACKET ASM-TAIL LAMP 113778-03-000 (2)  
SCREW G39-10-209 (4)  
GROMMET 23942-01-000 (2)
- REFLECTOR-RED 106646-02-000 (2)  
LOCATE REFLECTORS AS LOW AS POSSIBLE AND OUTBOARD WITHOUT GETTING INTO RADIUS OF BACK CAP BOTH SIDES

- ⑤V EXPORT ROOF AIR-7.00 BTU, 220VAC
- ②3K A/C ROOF-ONE 7,100 BTU
- ②6S CODES/STANDARDS-CSA/CMVSS
- ①B1 CODES STANDARDS/USA
- ④4L JAPAN EXPORT PACKAGE
- ①B1 ②6S ④4L 00 2220D