

- ③ SUPPLIED WITH CHASSIS.
- ② SEE WIRING DIAGRAM-AUTO LAMPS FOR ADDITIONAL INFORMATION.
- ① SEE SHT 2 OR 3 FOR ADDITIONAL INFORMATION.
- ④ SEE MANUFACTURER'S DIAGRAM FOR ADDITIONAL INFORMATION.

NOTES:

WIRING DIAGRAM-LEFT FRONT  
 (WIRE ASM 119011)

<b>WINNEBAGO</b>		95 221RC	
OPTN	UNSPECIFIED TOLERANCES ARE	MATERIAL	
CHRP	WIDE ORN 121		
FRK	ONE-PLATE 14 93		
INLE	ONE-PLATE 14 93		
INLE	ANGLE		
CONR	TRUSS ANGLE		
CONR	PROTECTION		
TITLE: WIRING DIAGRAM-BODY		DRAWN: 119010	
REV. DATE REVISION RECORD		SHEET 1 OF 5	

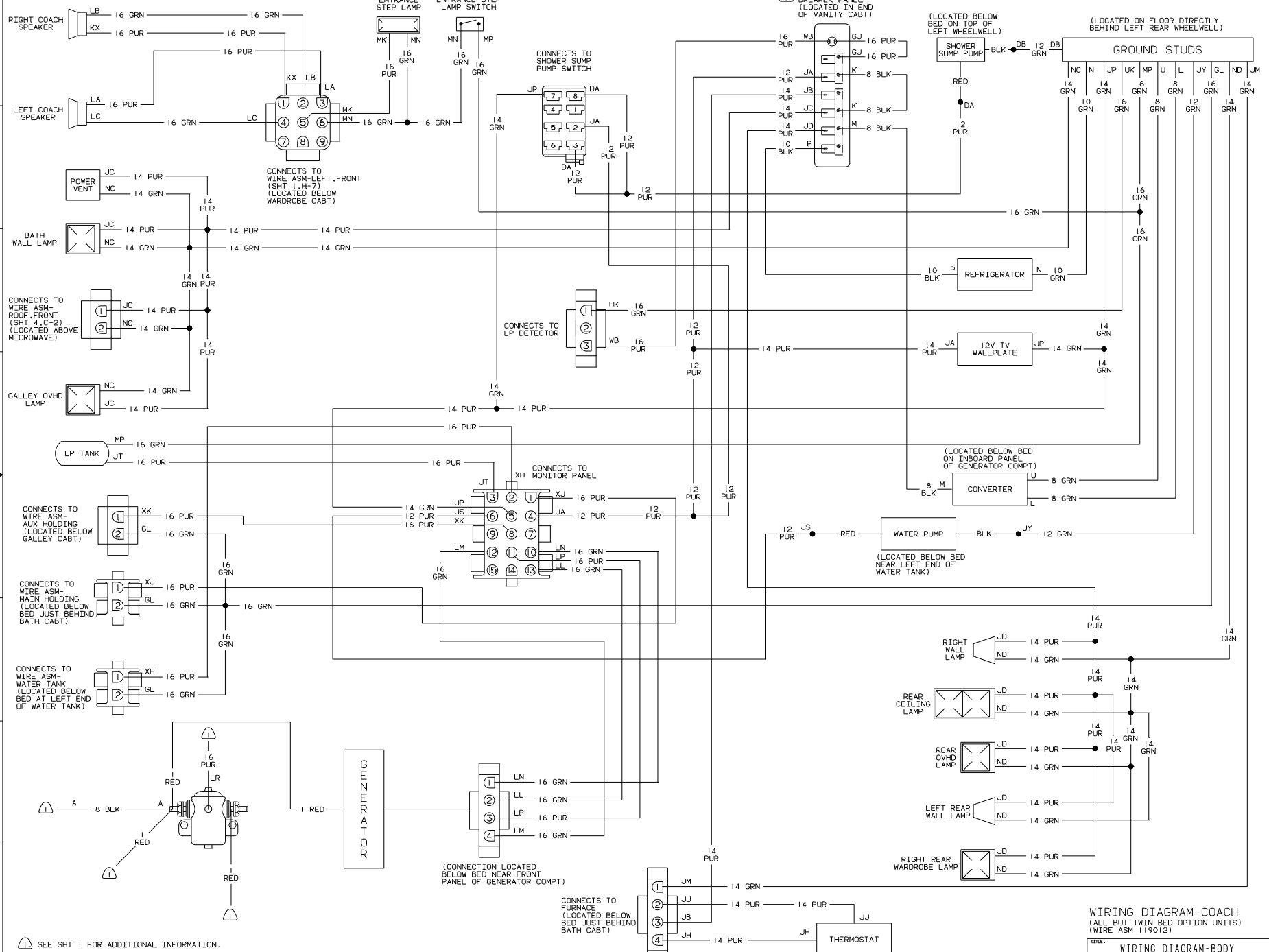

NOTES: SEE SHT 1 FOR ADDITIONAL INFORMATION.

WIRING DIAGRAM-COACH (ALL BUT TWIN BED OPTION UNITS) (WIRE ASM 119012)

TITLE:		WIRING DIAGRAM-BODY	
30 NET SCALE DRAWING	SHEET	2	OF 5
DATE	DESIGNED BY	11/11	11/11

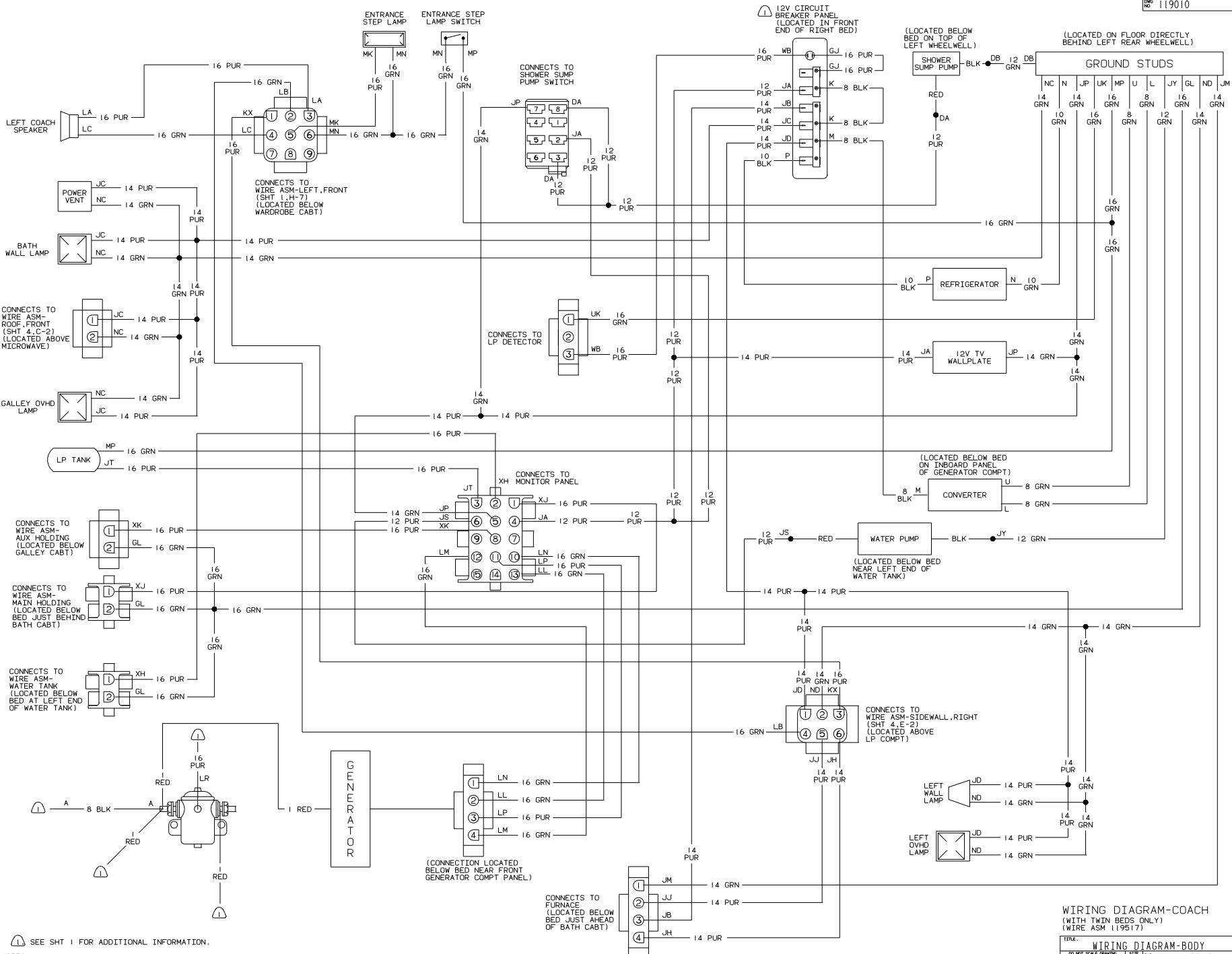

SEE SHIT 1 FOR ADDITIONAL INFORMATION.

NOTES:

WIRING DIAGRAM-COACH (WITH TWIN BEDS ONLY) (WIRE ASM 119517)

TITLE:		WIRING DIAGRAM-BODY	
30 NET SCALE DRAWING	SHEET	1	1
SHEET	3	OF	5
DATE		11/10	

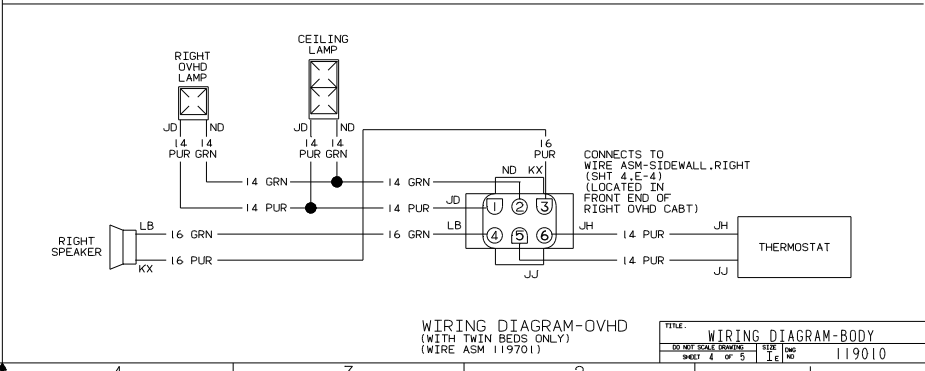
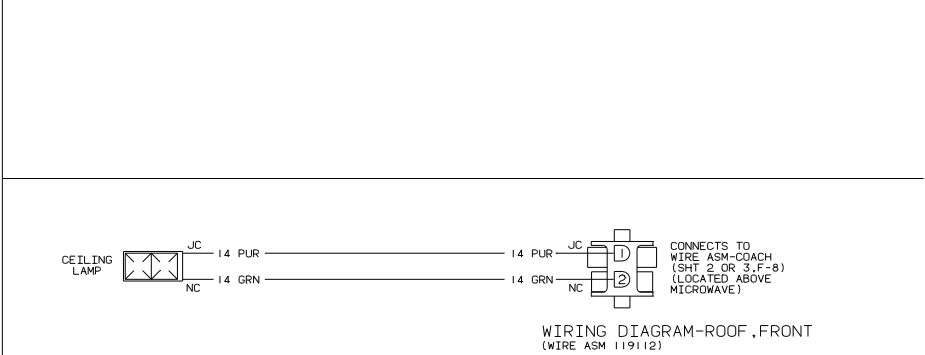
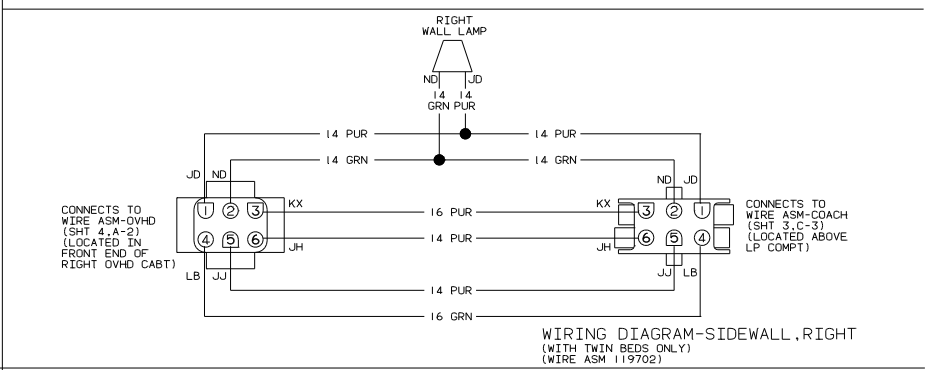
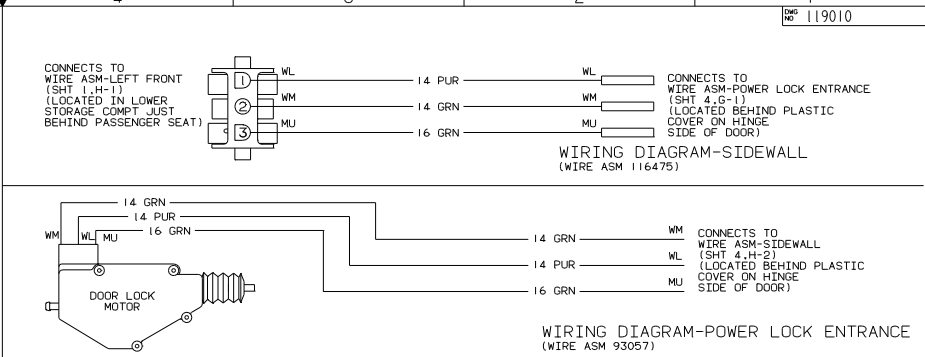
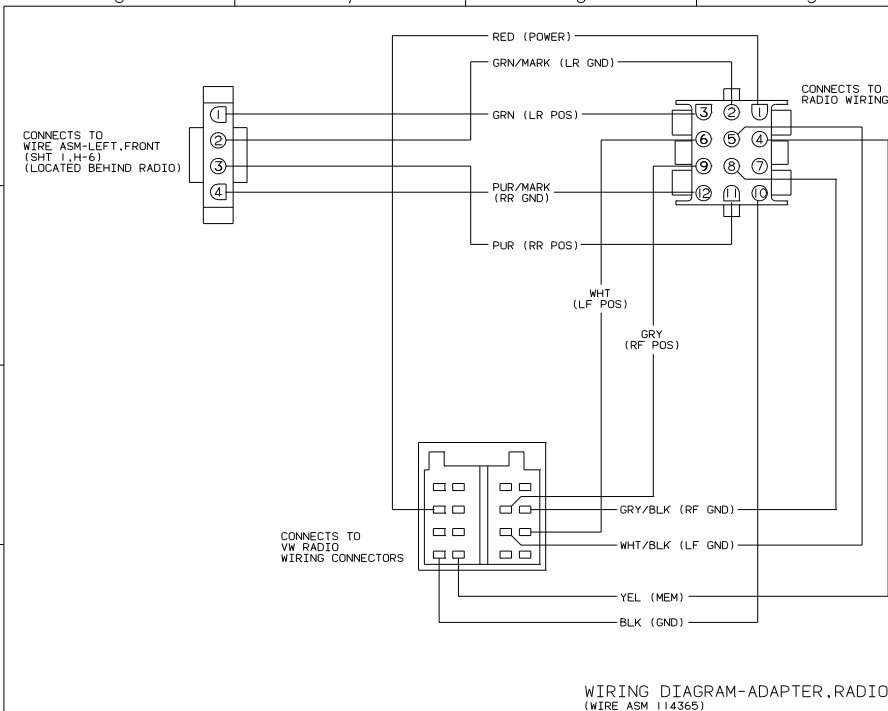

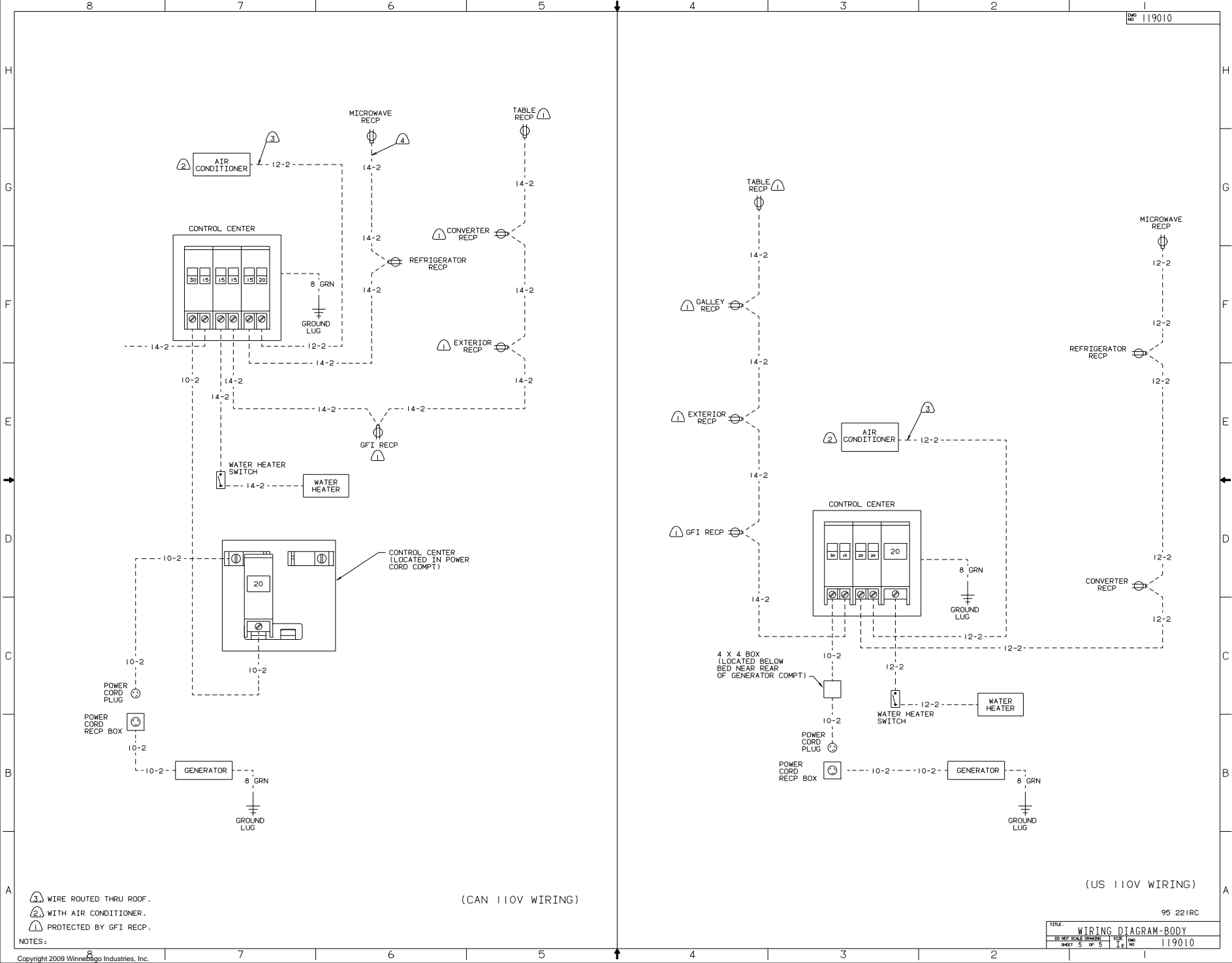

- ③ WIRE ROUTED THRU ROOF.
- ② WITH AIR CONDITIONER.
- ⚠ PROTECTED BY GFI RECP.

NOTES:

(CAN 110V WIRING)

(US 110V WIRING)

95 221RC

TITLE: WIRING DIAGRAM-BODY	
30 NET SCALE DRAWING	1/1
SHEET 5 OF 5	1/1
119010	