



DANGER

Danger of electrical shock, burns or death. Always remove all power sources before attempting any repair, service or diagnostic work. Power can be present from shore power, generator, inverter or battery. All power sources must be disabled and secured before performing any service.



CAUTION

If you lack the skills, tools or equipment to perform diagnostic or repair work leave such work to an authorized Winnebago Industries dealer or other qualified shop.

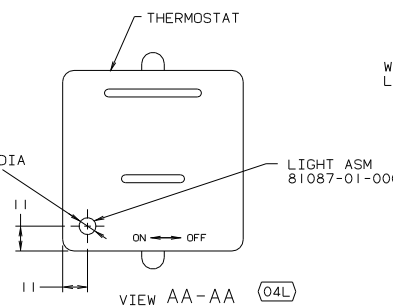
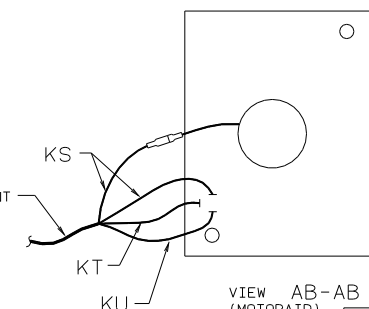
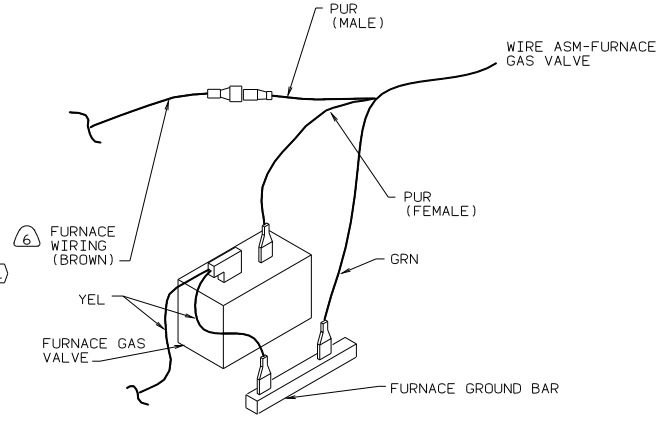
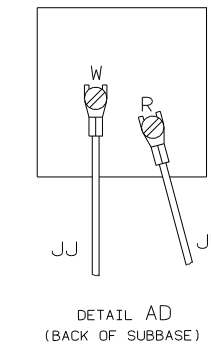
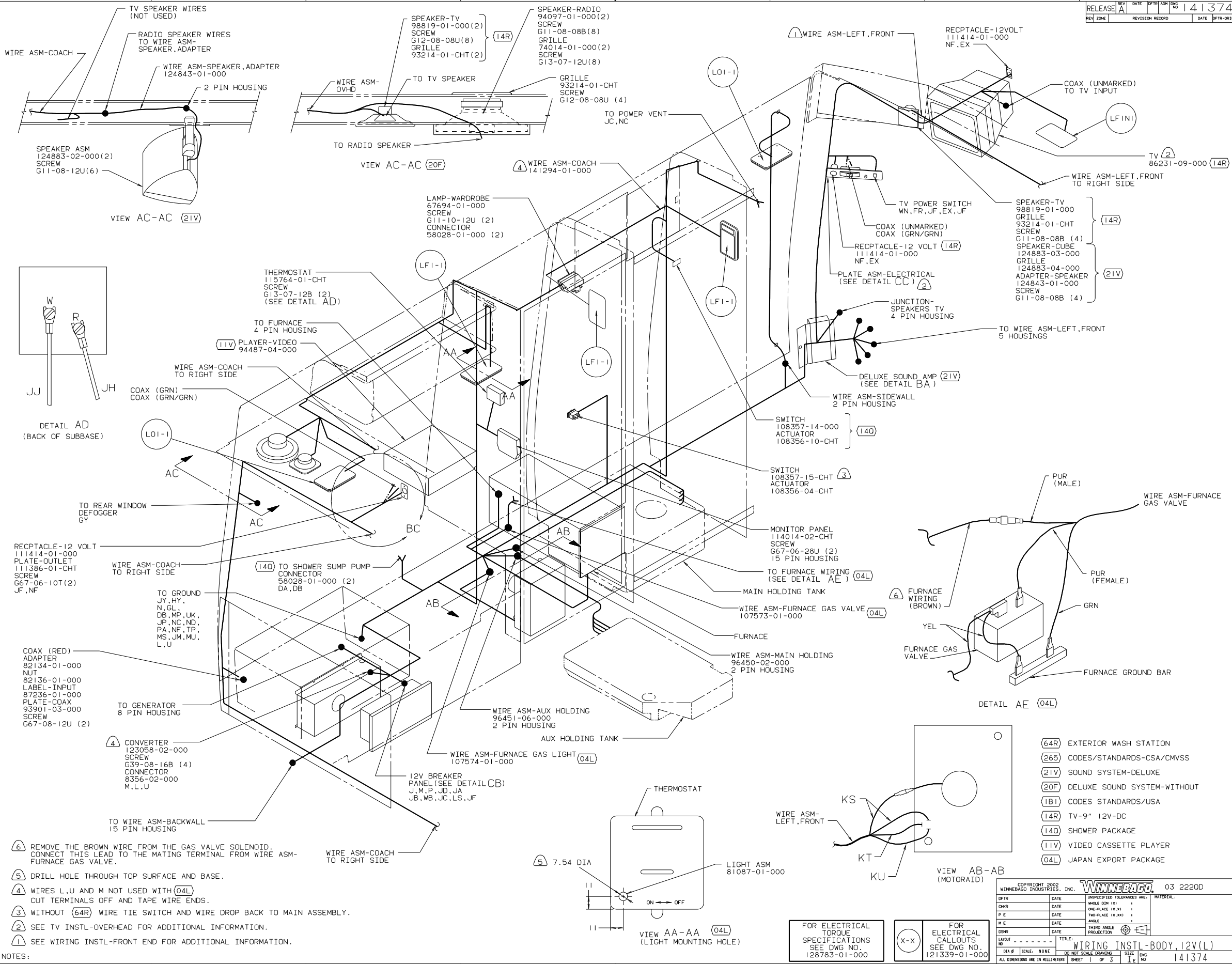

- NOTES:
- ⑥ REMOVE THE BROWN WIRE FROM THE GAS VALVE SOLENOID. CONNECT THIS LEAD TO THE MATING TERMINAL FROM WIRE ASM-FURNACE GAS VALVE.
 - ⑤ DRILL HOLE THROUGH TOP SURFACE AND BASE.
 - ④ WIRES L,U AND M NOT USED WITH (04L) CUT TERMINALS OFF AND TAPE WIRE ENDS.
 - ③ WITHOUT (64R) WIRE TIE SWITCH AND WIRE DROP BACK TO MAIN ASSEMBLY.
 - ② SEE TV INSTL-OVERHEAD FOR ADDITIONAL INFORMATION.
 - ① SEE WIRING INSTL-FRONT END FOR ADDITIONAL INFORMATION.

- (64R) EXTERIOR WASH STATION
- (265) CODES/STANDARDS-CSA/CMVSS
- (21V) SOUND SYSTEM-DELUXE
- (20F) DELUXE SOUND SYSTEM-WITHOUT
- (1B1) CODES STANDARDS/USA
- (14R) TV-9" 12V-DC
- (14D) SHOWER PACKAGE
- (11V) VIDEO CASSETTE PLAYER
- (04L) JAPAN EXPORT PACKAGE

FOR ELECTRICAL TORQUE SPECIFICATIONS SEE DWG NO. 128783-01-000

FOR ELECTRICAL CALLOUTS SEE DWG NO. 121339-01-000

COPYRIGHT 2002 WINNEBAGO INDUSTRIES, INC. 03 2220D		MATERIAL:	
DTR	DATE	UNSPECIFIED TOLERANCES ARE:	
CHR	DATE	ANGLE DIM (XX)	+
P E	DATE	ONE-PLACE (X,XX)	+
M E	DATE	TWO-PLACE (X,XX)	+
DNR	DATE	THIRD ANGLE PROJECTION	+
LAYOUT NO. -----		TITLE: WIRING INSTL-BODY, 12V(L)	
DIA #	SCALE: NONE	DO NOT SCALE DRAWING	SHEET NO. 141374
ALL DIMENSIONS ARE IN MILLIMETERS		SHEET 1 OF 3	

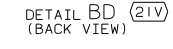
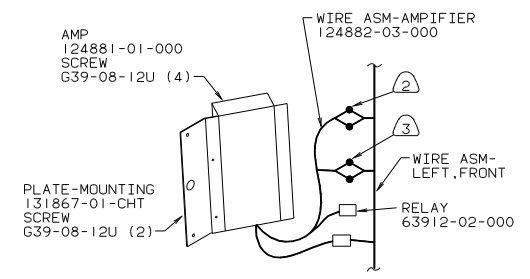
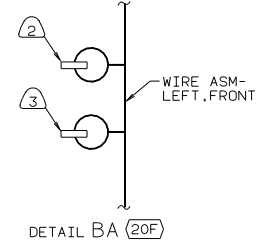
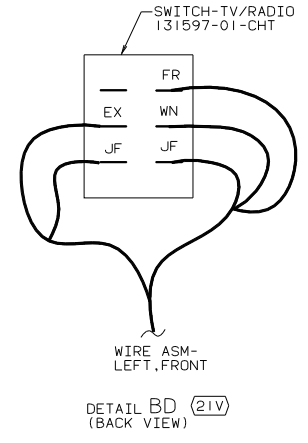
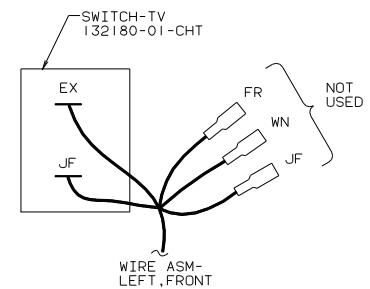
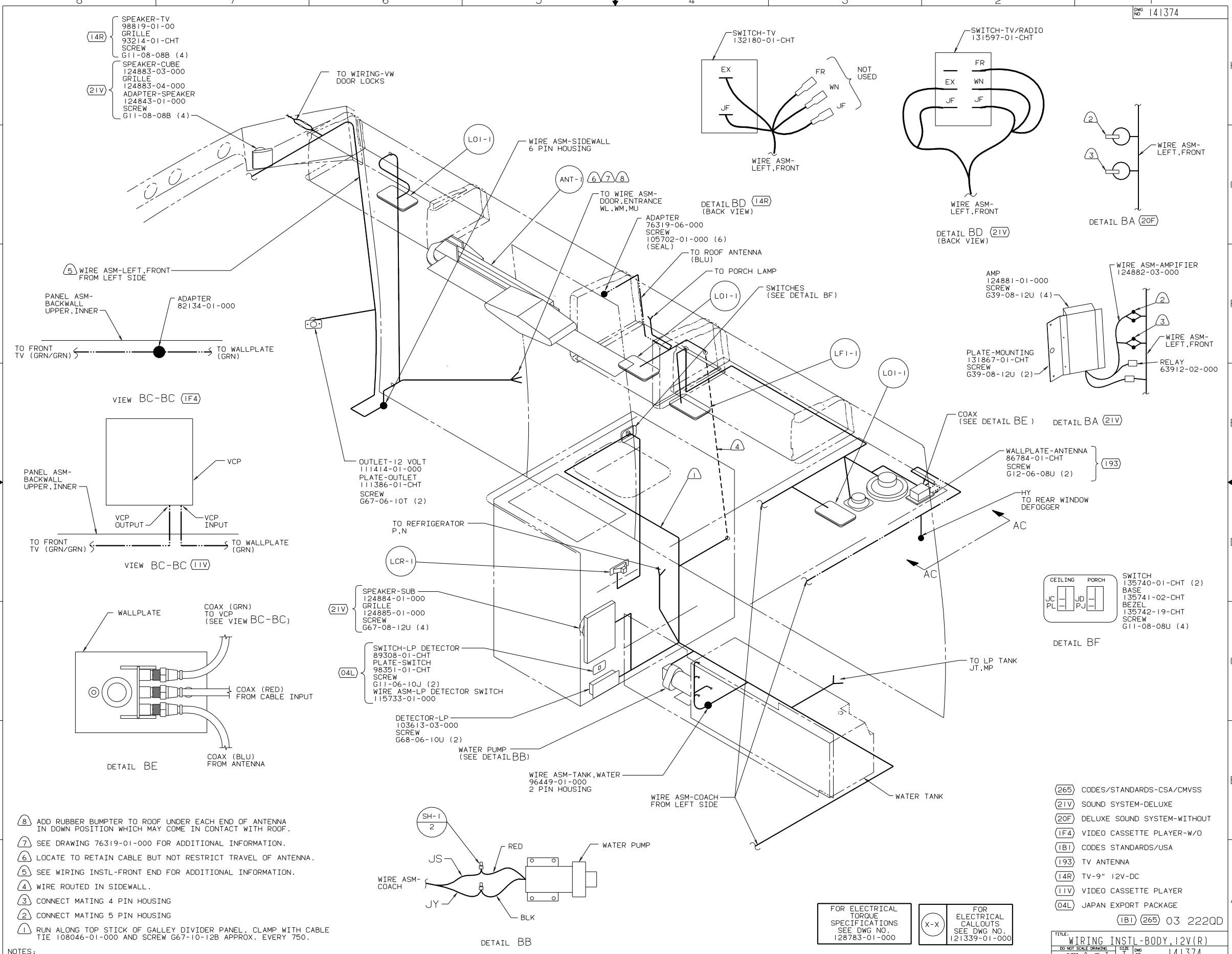

- (14R) {
 - SPEAKER-TV 98819-01-00
 - GRILLE 93214-01-CHT
 - SCREW G11-08-08B (4)
- (21V) {
 - SPEAKER-CUBE 124883-03-000
 - GRILLE 124883-04-000
 - ADAPTER-SPEAKER 124843-01-000
 - SCREW G11-08-08B (4)

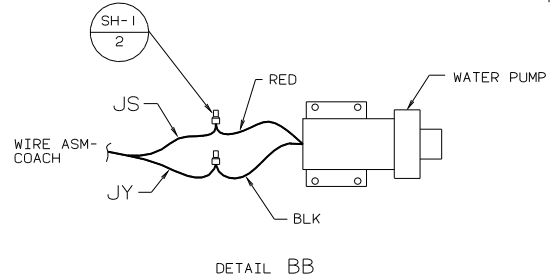
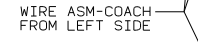
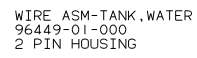
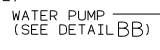
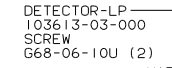
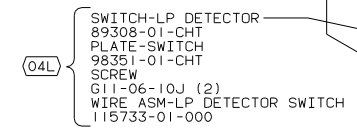
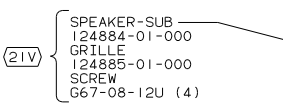
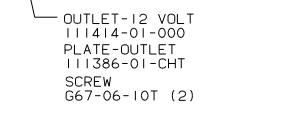
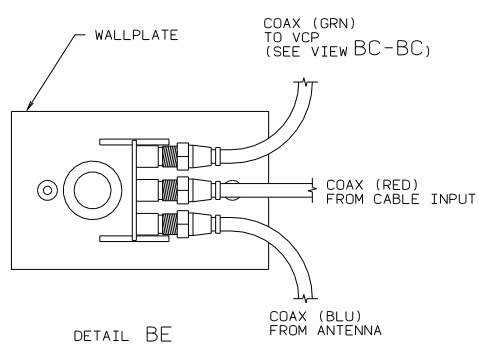
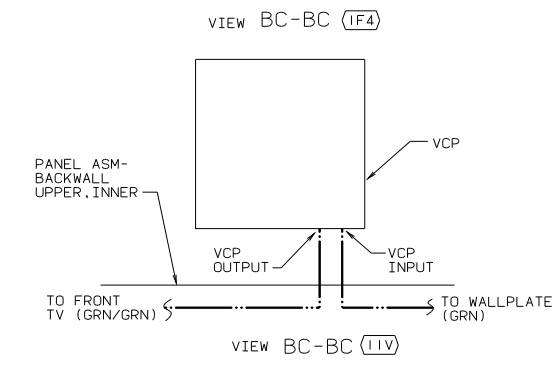
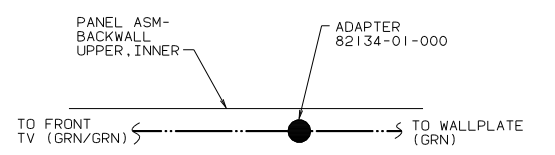

- (8) ADD RUBBER BUMPTER TO ROOF UNDER EACH END OF ANTENNA IN DOWN POSITION WHICH MAY COME IN CONTACT WITH ROOF.
- (7) SEE DRAWING 76319-01-000 FOR ADDITIONAL INFORMATION.
- (6) LOCATE TO RETAIN CABLE BUT NOT RESTRICT TRAVEL OF ANTENNA.
- (5) SEE WIRING INSTL-FRONT END FOR ADDITIONAL INFORMATION.
- (4) WIRE ROUTED IN SIDEWALL.
- (3) CONNECT MATING 4 PIN HOUSING
- (2) CONNECT MATING 5 PIN HOUSING
- (1) RUN ALONG TOP STICK OF GALLEY DIVIDER PANEL. CLAMP WITH CABLE TIE 108046-01-000 AND SCREW G67-10-12B APPROX. EVERY 750.

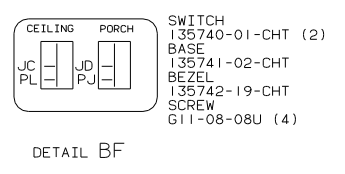

- (265) CODES/STANDARDS-CSA/CMVSS
- (21V) SOUND SYSTEM-DELUXE
- (20F) DELUXE SOUND SYSTEM-WITHOUT
- (1F4) VIDEO CASSETTE PLAYER-W/O
- (1B1) CODES STANDARDS/USA
- (193) TV ANTENNA
- (14R) TV-9" 12V-DC
- (11V) VIDEO CASSETTE PLAYER
- (04L) JAPAN EXPORT PACKAGE

FOR ELECTRICAL TORQUE SPECIFICATIONS SEE DWG NO. 128783-01-000

FOR ELECTRICAL CALLOUTS SEE DWG NO. 121339-01-000

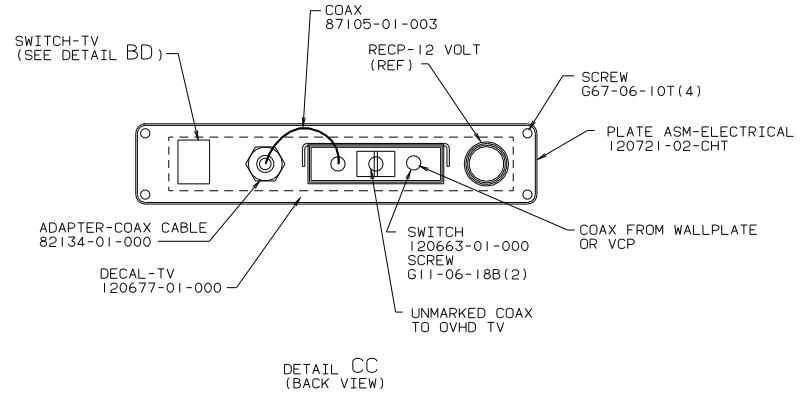
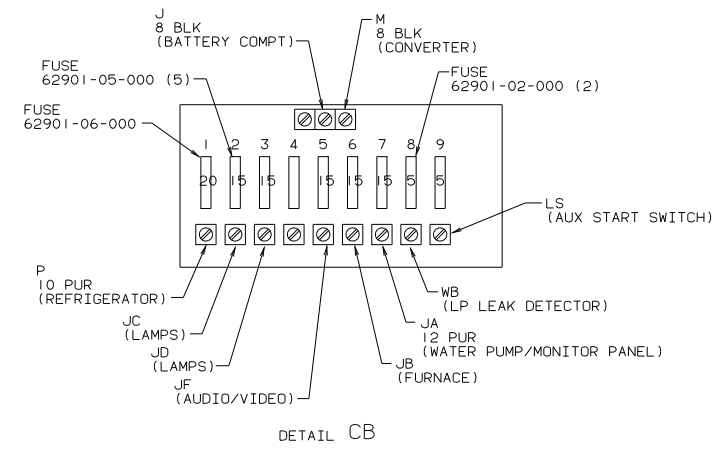

FOR ELECTRICAL TORQUE SPECIFICATIONS SEE DWG NO. 128783-01-000

(265) CODES/STANDARDS-CSA/CMVSS
 (1B1) CODES STANDARDS/USA
 (04L) JAPAN EXPORT PACKAGE
 (1B1) (265) (04L) 03 2220D

TITLE		WIRING INSTL-BODY, 12V(EXT)	
DO NOT SCALE DRAWING	SIZE	DWG NO	141374
SHEET 3 OF 3	IE		

NOTES: