



DANGER

Danger of electrical shock, burns or death. Always remove all power sources before attempting any repair, service or diagnostic work. Power can be present from shore power, generator, inverter or battery. All power sources must be disabled and secured before performing any service.



CAUTION

If you lack the skills, tools or equipment to perform diagnostic or repair work leave such work to an authorized Winnebago Industries dealer or other qualified shop.

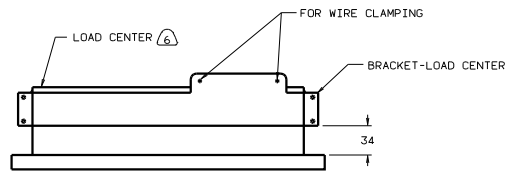

VIEW AA-AA

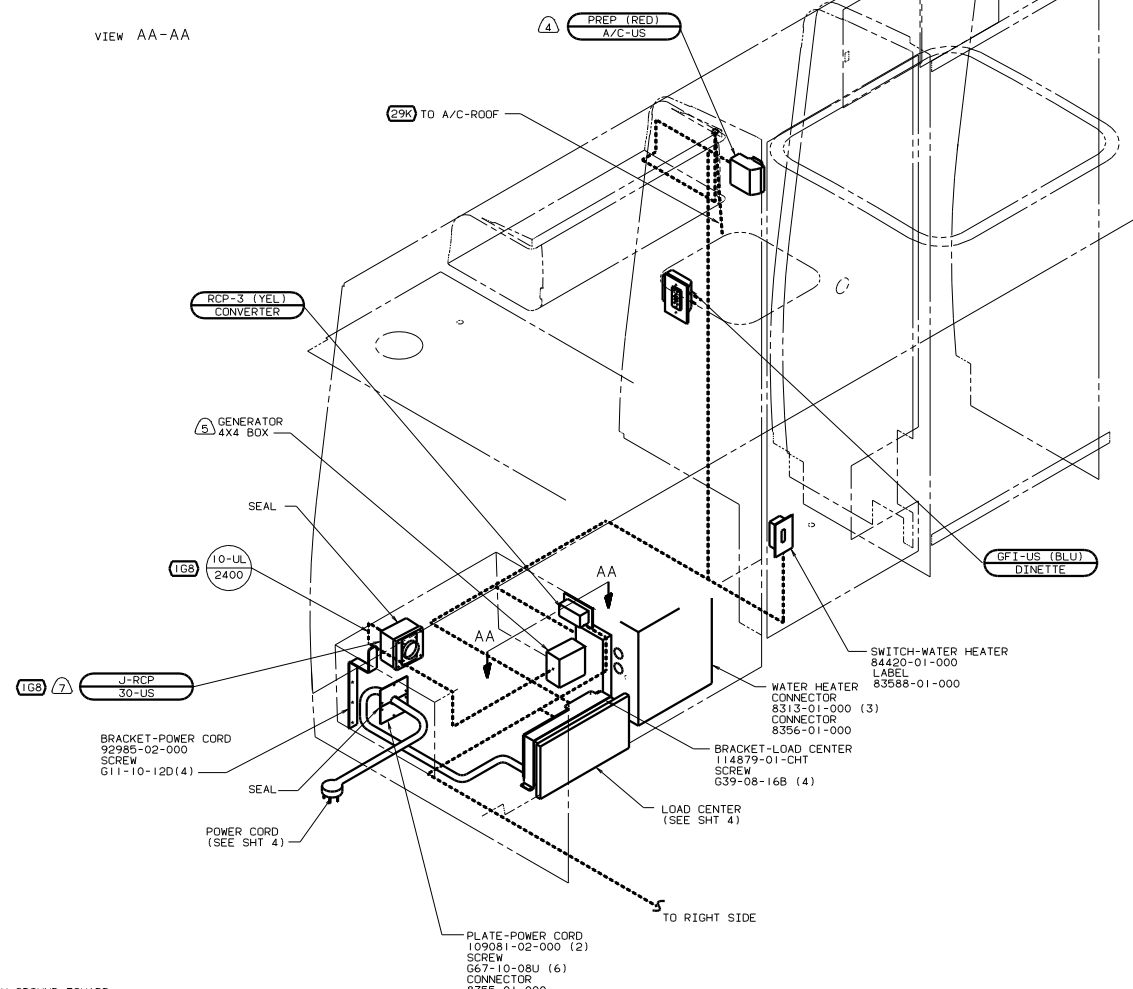

- (7) INSTALL RCP WITH GROUND TOWARD BOTTOM OF VEHICLE.
 - (6) LOCATE LOAD CENTER WITHIN DINETTE SEAT FACE.
 - (5) SEE GENERATOR INSTL FOR ADDITIONAL INFORMATION.
 - (4) NOT USED WITH (29K)
3. ALL GROUND WIRES TO BE COVERED WITH TUBING 8041-02-000.
2. ALL WIRES ARE TO BE CLAMPED WITH CLAMP 10497-05-000 WITHIN 200 OF OUTLET BOXES. USE SCREW G67-10-12B.
1. ALL WIRES TO BE CLAMPED WITH CLAMP 10495-01-000 OR CLIP 80734-01-000 EVERY 600. USE SCREW G67-10-12B UNLESS OTHERWISE SPECIFIED.

NOTES:

- (29K) A/C ROOF-ONE 7.100 BTU
- (1B1) CODES STANDARDS/USA
- (1G8) GEN-2.8KW ONAN MICROLITE
- (12D) ELECTRICAL SYSTEM 30 AMP

FOR ELECTRICAL TORQUE SPECIFICATIONS SEE DWG NO. 128783-01-000	(X-X)	FOR ELECTRICAL CALLOUTS SEE DWG NO. 121339-01-000
----------------------------------------------------------------	-------	---------------------------------------------------

WINNEBAGO 00 22200

OF IN	DATE	UNSPECIFIED TOLERANCES ARE:	MATERIAL
DRP	DATE	WHOLE OR .01	
DFE	DATE	ONE-PLACE (X.X1)	
DVE	DATE	TWO-PLACE (X.XX)	
DDP	DATE	THREE-PLACE (X.XXX)	
DDF	DATE	THREE-PLACE (X.XXX)	
DDV	DATE	THREE-PLACE (X.XXX)	
DDW	DATE	THREE-PLACE (X.XXX)	
DDX	DATE	THREE-PLACE (X.XXX)	
DDY	DATE	THREE-PLACE (X.XXX)	
DDZ	DATE	THREE-PLACE (X.XXX)	

WIRING INSTL - BODY, 110V (130US)
 REF: 130479-N 1
 SHEET 1 OF 3
 133421

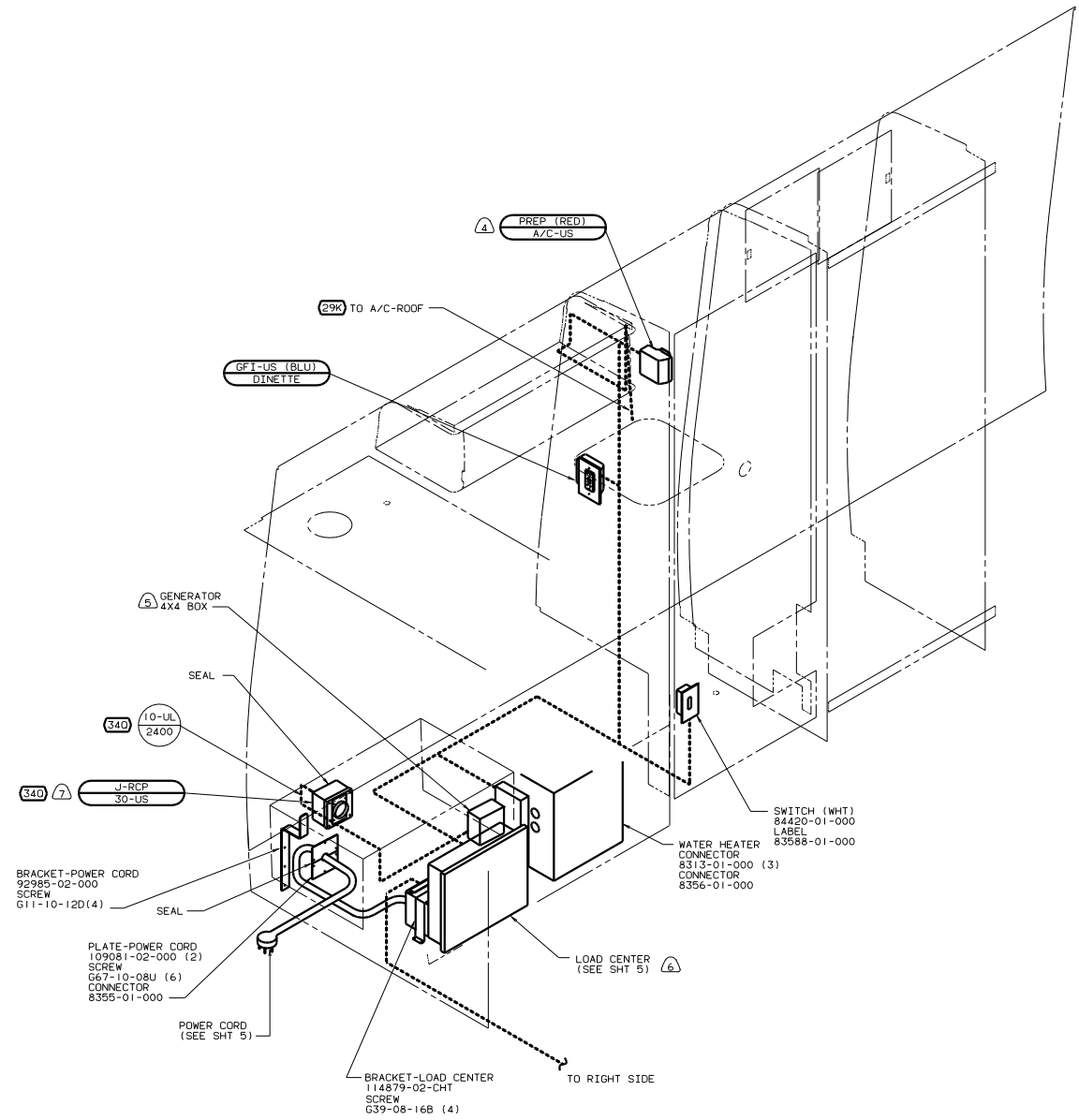

- NOTES:
1. ALL WIRES TO BE CLAMPED WITH CLAMP 10495-01-000 OR CLIP 80734-01-000 EVERY 600, USE SCREW G67-10-12B UNLESS OTHERWISE SPECIFIED.
 2. ALL WIRES ARE TO BE CLAMPED WITH CLAMP 10497-05-000 WITHIN 200 OF OUTLET BOXES, USE SCREW G67-10-12B.
 3. ALL GROUND WIRES TO BE COVERED WITH TUBING 8041-02-000.

- (7) INSTALL RCP WITH GROUND TOWARD BOTTOM OF VEHICLE.
- (6) LOCATE LOAD CENTER WITHIN DINETTE SEAT FACE.
- (5) SEE GENERATOR INSTL FOR ADDITIONAL INFORMATION.
- (4) NOT USED WITH (29K)

- (340) GEN-3.0KW GENERAC 100V
- (29K) A/C ROOF-ONE 7,100 BTU
- (12D) ELECTRICAL SYSTEM 30 AMP
- (04L) JAPAN EXPORT PACKAGE

(04L) (12D) 00 2220D

FOR ELECTRICAL TORQUE SPECIFICATIONS SEE DWG NO. 128783-01-000

FOR ELECTRICAL CALLOUTS SEE DWG NO. 121339-01-000

WIRING INSTL-BODY, 110V(L30JPN)
 SHEET 2 OF 3
 133421

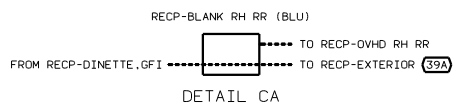
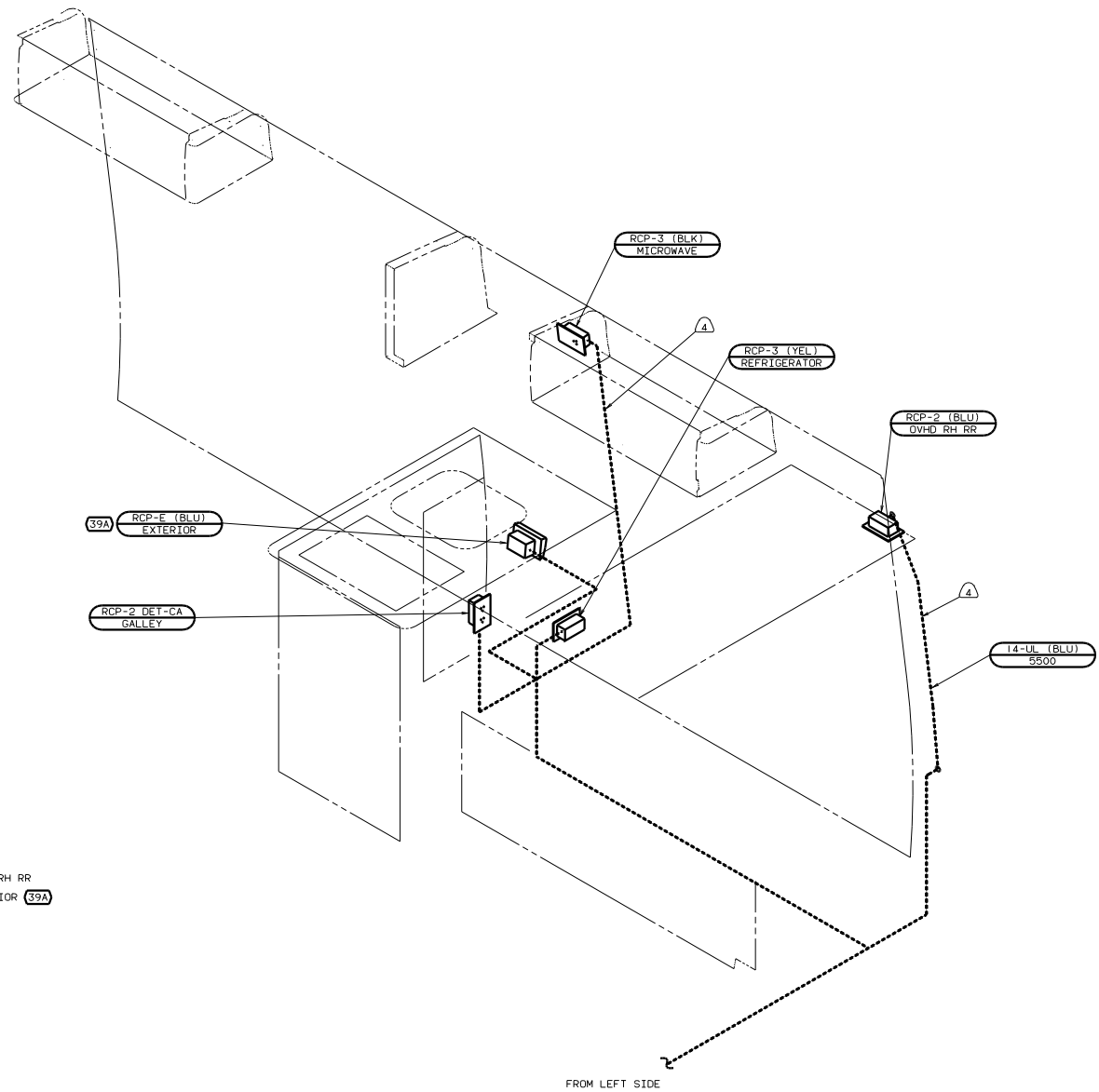

- NOTES:
- 1. ALL WIRES TO BE CLAMPED WITH CLAMP 10495-01-000 OR CLIP 80734-01-000 EVERY 600. USE SCREW G67-10-12B UNLESS OTHERWISE SPECIFIED.
 - 2. ALL WIRES ARE TO BE CLAMPED WITH CLAMP 10497-05-000 WITHIN 200 OF OUTLET BOXES. USE SCREW G67-10-12B.
 - 3. ALL GROUND WIRES TO BE COVERED WITH TUBING 8041-02-000.
- △ ROUTE WIRE THRU SIDEWALL.

FOR ELECTRICAL TORQUE SPECIFICATIONS SEE DWG NO. 128783-01-000

FOR ELECTRICAL CALLOUTS SEE DWG NO. 121339-01-000

- (39A) EXT RECEPTACLE DPLX 120VAC
- (1B1) CODES STANDARDS/USA
- (12D) ELECTRICAL SYSTEM 30 AMP
- (04L) JAPAN EXPORT PACKAGE

(1B1) (04L) (12D) 00 2220D

WIRING INSTL - BODY, 110V (R30US)
 SHEET 3 OF 9
 133421

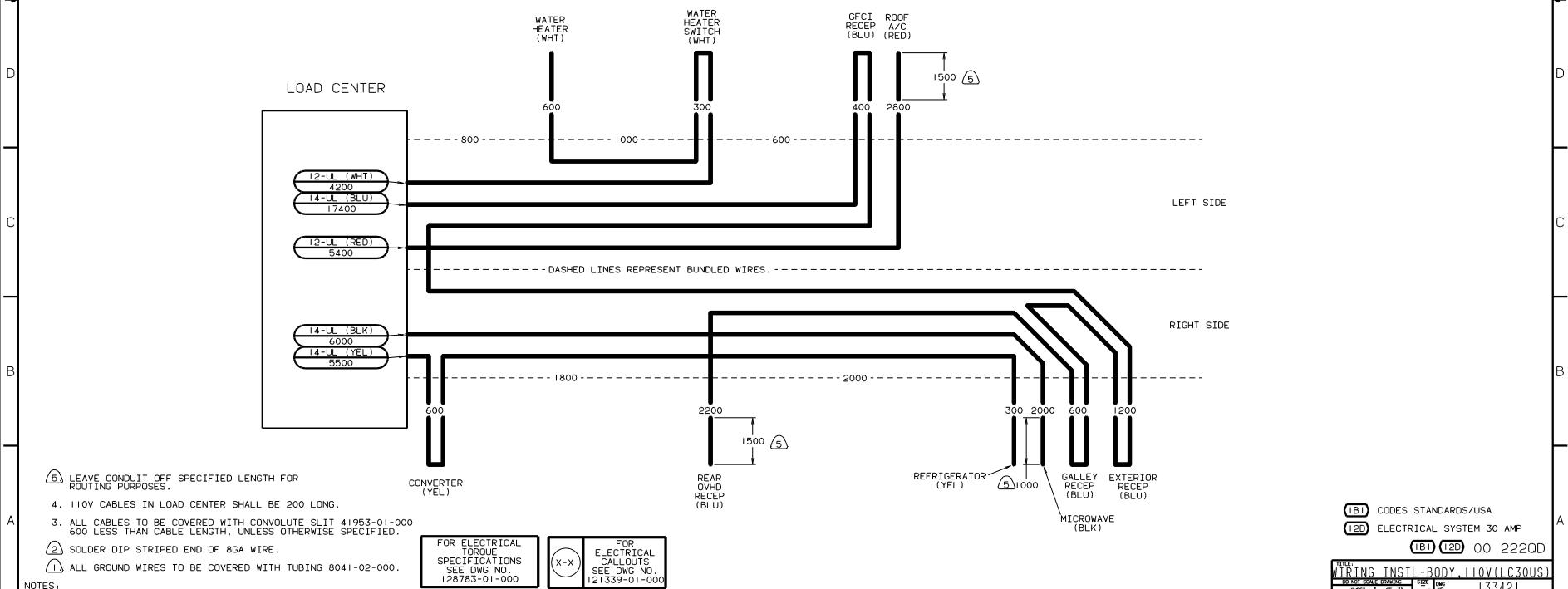
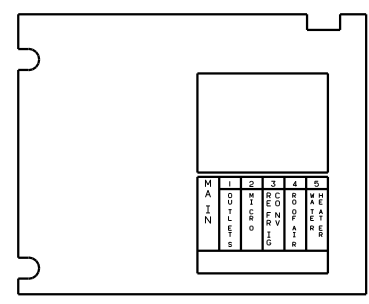
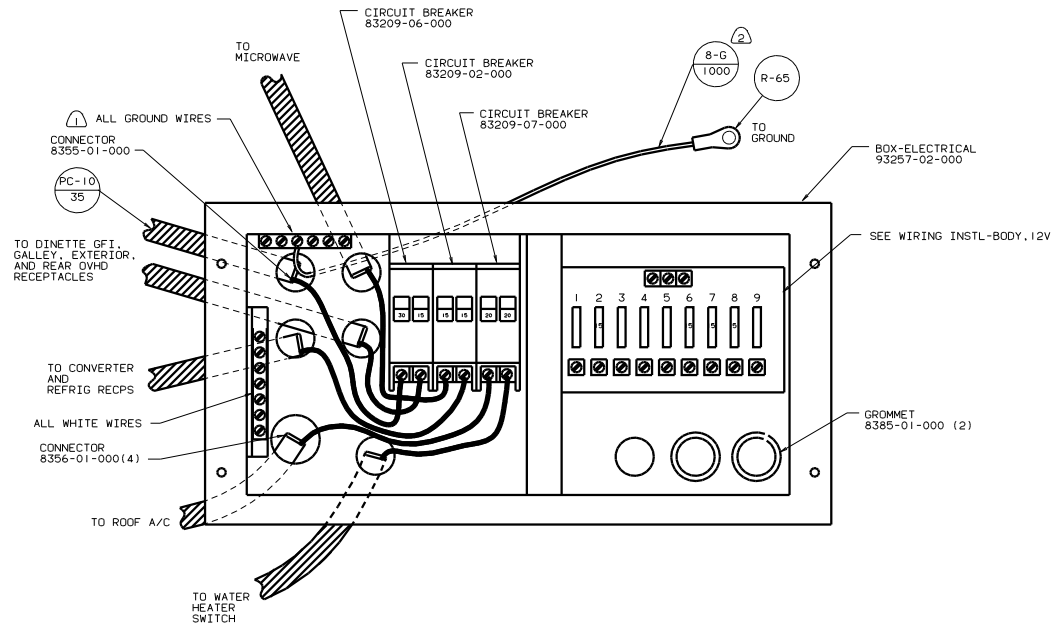

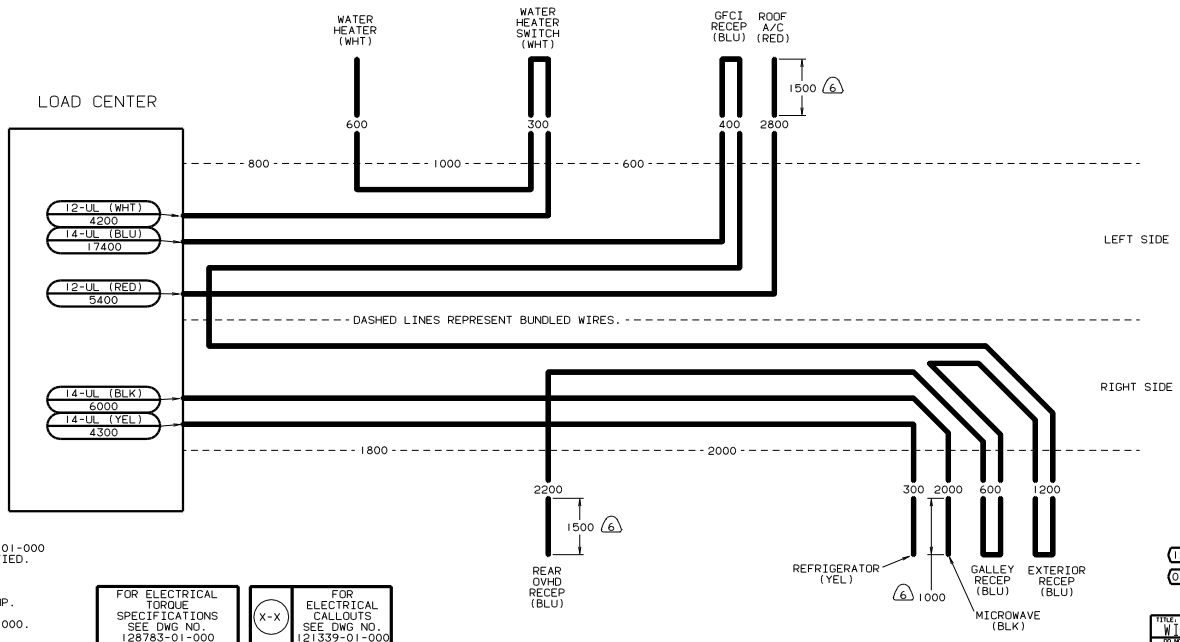
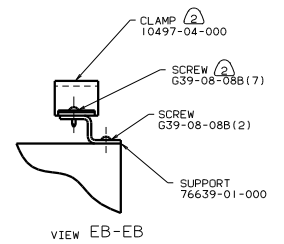
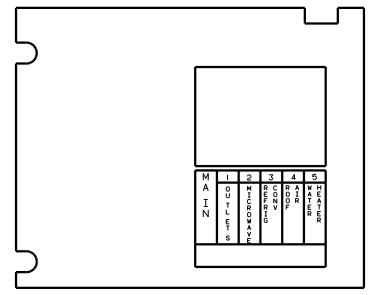
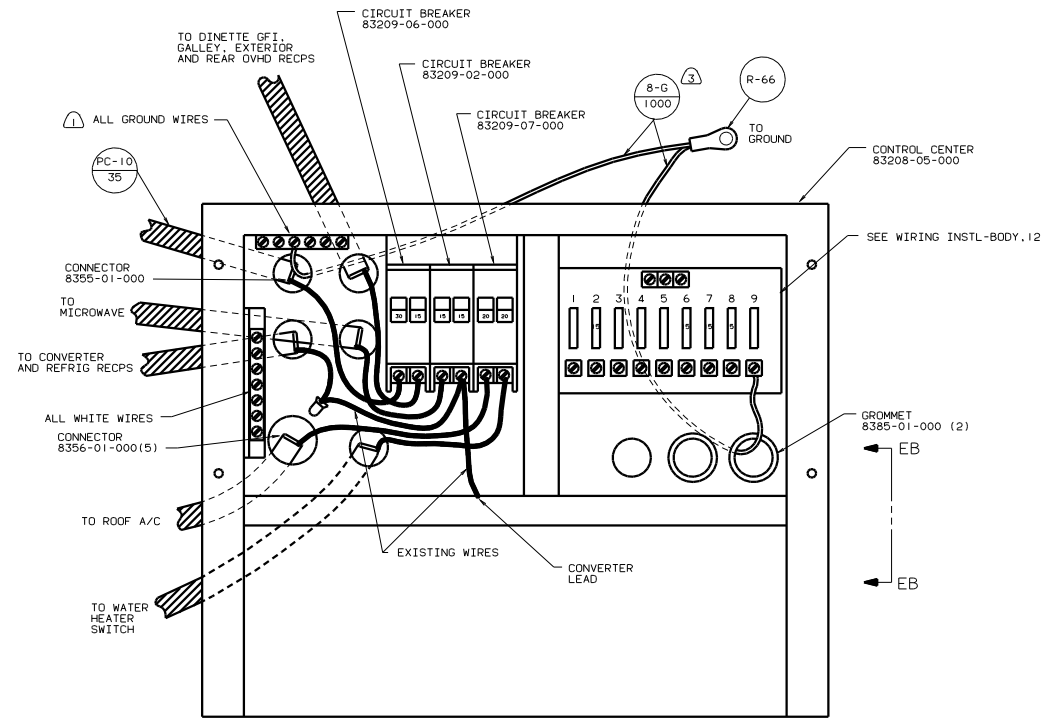

6. LEAVE CONDUIT OFF SPECIFIED LENGTH FOR ROUTING PURPOSES.
5. 110V CABLES IN LOAD CENTER SHALL BE 200 LONG.
4. ALL CABLES TO BE COVERED WITH CONVOLUTE SLIT 41953-01-000 600 LESS THAN CABLE LENGTH, UNLESS OTHERWISE SPECIFIED.
3. SOLDER DIP STRIPPED ENDS OF 8GA WIRES.
2. FASTEN ALL WIRES TO SUPPORT. USE ONE SCREW PER CLAMP.
1. ALL GROUND WIRES TO BE COVERED WITH TUBING 8041-02-000.

FOR ELECTRICAL TORQUE SPECIFICATIONS SEE DWG NO. 128783-01-000	(X-X)	FOR ELECTRICAL CALLOUTS SEE DWG NO. 121339-01-000
----------------------------------------------------------------	-------	---------------------------------------------------

(12D) ELECTRICAL SYSTEM 30 AMP

(04L) JAPAN EXPORT PACKAGE

(04L) (12D) 00 2220D

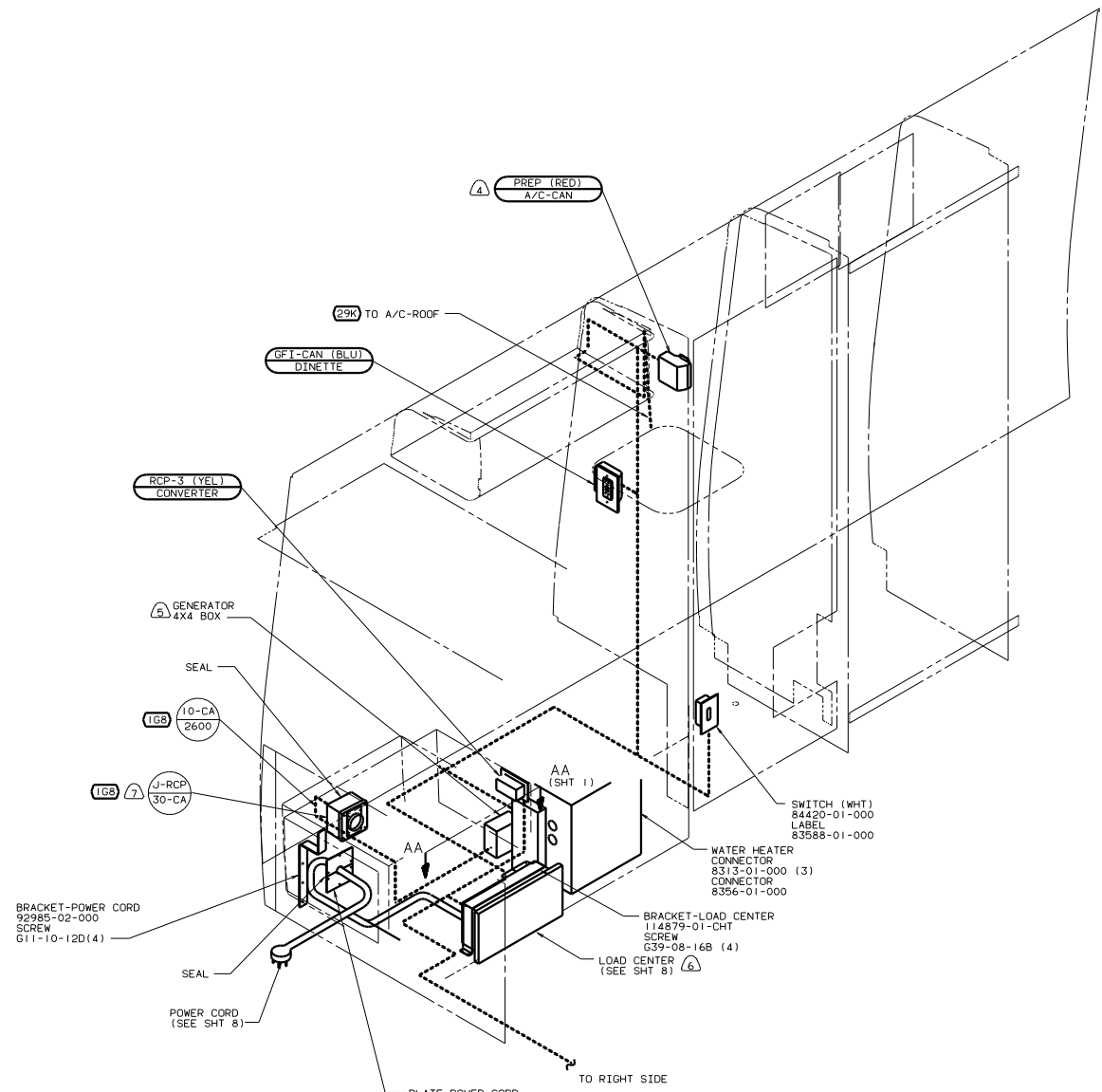

- NOTES:
1. ALL WIRES TO BE CLAMPED WITH CLAMP 10495-01-000 OR CLIP 80734-01-000 EVERY 600. USE SCREW G67-10-12B UNLESS OTHERWISE SPECIFIED.
 2. ALL WIRES ARE TO BE CLAMPED WITH CLAMP 10497-05-000 WITHIN 200 OF OUTLET BOXES. USE SCREW G67-10-12B.
 3. ALL GROUND WIRES TO BE COVERED WITH TUBING 8011-02-000.

4. NOT USED WITH (29K)
5. SEE GENERATOR INSTL FOR ADDITIONAL INFORMATION.
6. LOCATE LOAD CENTER WITHIN DINETTE SEAT FACE.
7. INSTALL RECP WITH GROUND TOWARD BOTTOM OF VEHICLE.

PLATE-POWER CORD
109081-02-000 (2)
SCREW
G67-10-08U (6)
CONNECTOR
8355-01-000

FOR ELECTRICAL TORQUE SPECIFICATIONS SEE DWG NO. 128783-01-000

FOR ELECTRICAL CALLOUTS SEE DWG NO. 121339-01-000

- (29K) A/C ROOF-ONE 7.100 BTU
- (26S) CODES/STANDARDS-CSA/CMVSS
- (1G8) GEN-2.8KW ONAN MICROLITE
- (12D) ELECTRICAL SYSTEM 30 AMP

WIRING INSTL-BODY, 110V(130CA)
SHEET 6 OF 9
133421

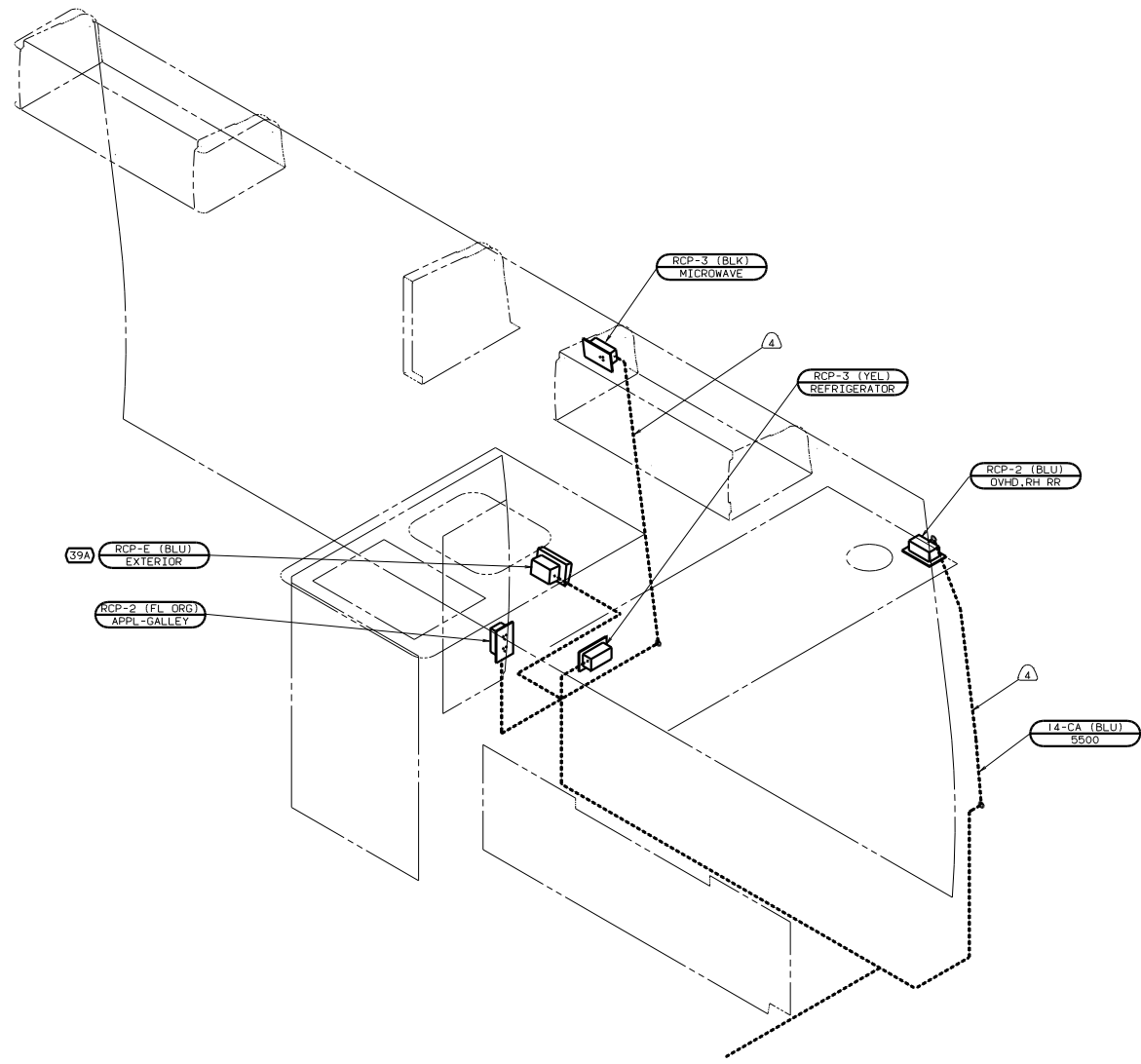

FROM LEFT SIDE

- 4) ROUTE WIRE THRU SIDEWALL.
- 3. ALL GROUND WIRES TO BE COVERED WITH TUBING 8011-02-000.
- 2. ALL WIRES ARE TO BE CLAMPED WITH CLAMP 10497-05-000 WITHIN 200 OF OUTLET BOXES. USE SCREW G67-10-12B.
- 1. ALL WIRES TO BE CLAMPED WITH CLAMP 10495-01-000 OR CLIP 80734-01-000 EVERY 600. USE SCREW G67-10-12B UNLESS OTHERWISE SPECIFIED.

NOTES:

FOR ELECTRICAL TORQUE SPECIFICATIONS SEE DWG NO. 128783-01-000



FOR ELECTRICAL CALLOUTS SEE DWG NO. 121339-01-000

- 39A EXT RECEPTACLE DPLX 120VAC
- 265 CODES/STANDARDS-CSA/CMVSS
- 120 ELECTRICAL SYSTEM 30 AMP
- 265 120 00 22200

WIRING INSTL - BODY 110V (R30CA)
 SHEET 7 OF 9
 133421

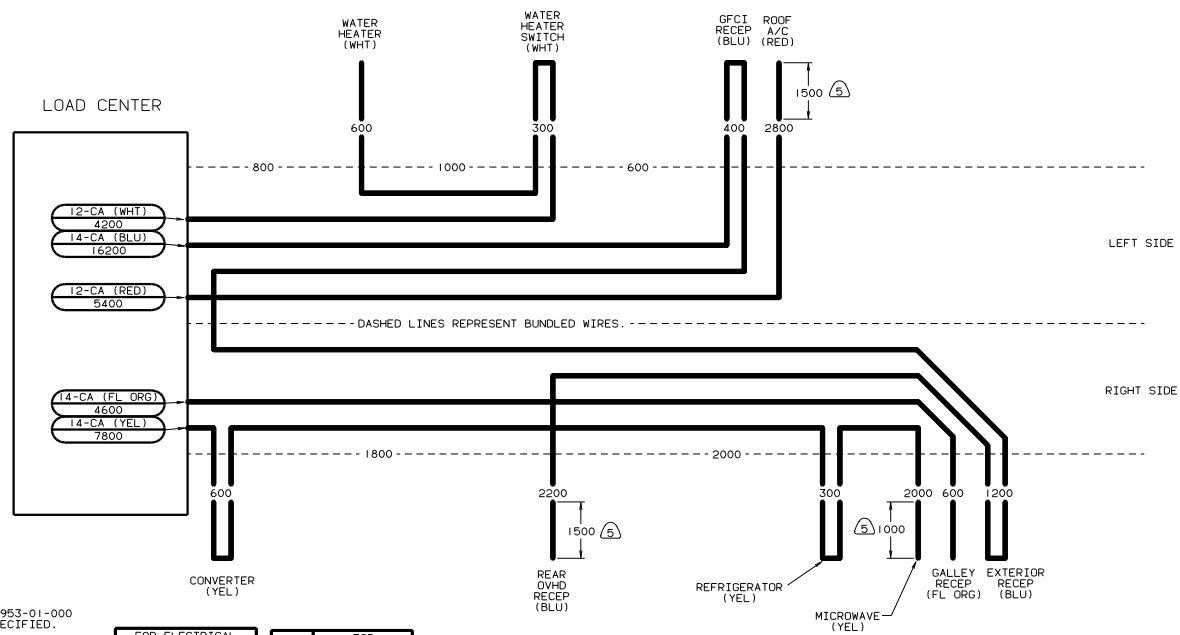
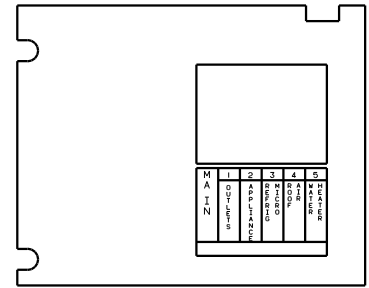
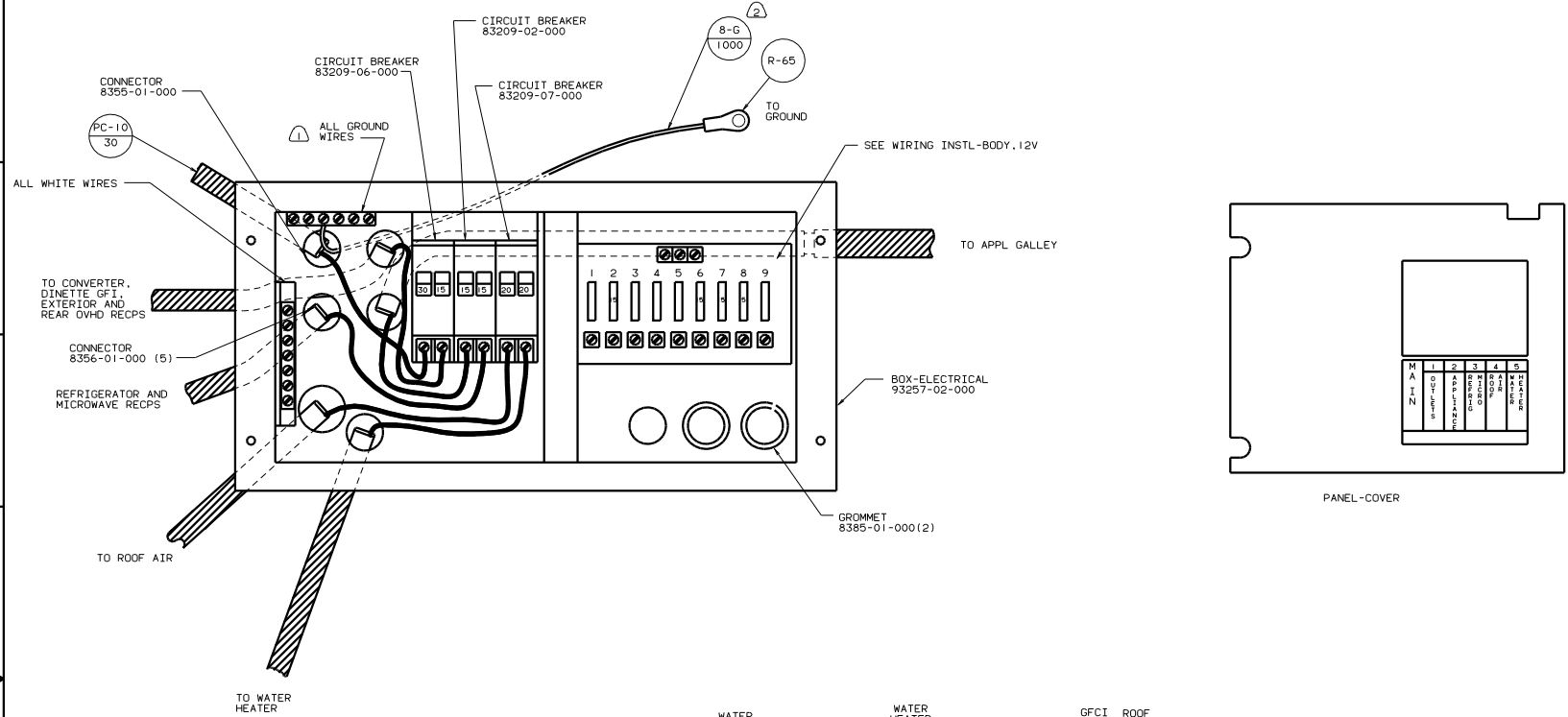

- Ⓜ LEAVE CONDUIT OFF SPECIFIED LENGTH FOR ROUTING PURPOSES.
4. 110V CABLES IN LOAD CENTER SHALL BE 200 LONG.
3. ALL CABLES TO BE COVERED WITH CONVOLUTE SLIT 41953-01-000 600 LESS THAN CABLE LENGTH, UNLESS OTHERWISE SPECIFIED.
- Ⓜ SOLDER DIP STRIPED END OF 8GA WIRE.
- Ⓜ ALL GROUND WIRES TO BE COVERED WITH TUBING 8041-02-000.

FOR ELECTRICAL TORQUE SPECIFICATIONS SEE DWG NO. 128783-01-000	(X-X)	FOR ELECTRICAL CALLOUTS SEE DWG NO. 121339-01-000
----------------------------------------------------------------	-------	---------------------------------------------------

Ⓜ CODES/STANDARDS-CSA/CMVSS

Ⓜ ELECTRICAL SYSTEM 30 AMP

Ⓜ Ⓜ 00 2220D

FILE: WIRING INSTL-BODY.110V(LC30CA)

30 25 20 15 10 5

SHEET 8 of 9

DWG NO. 133421

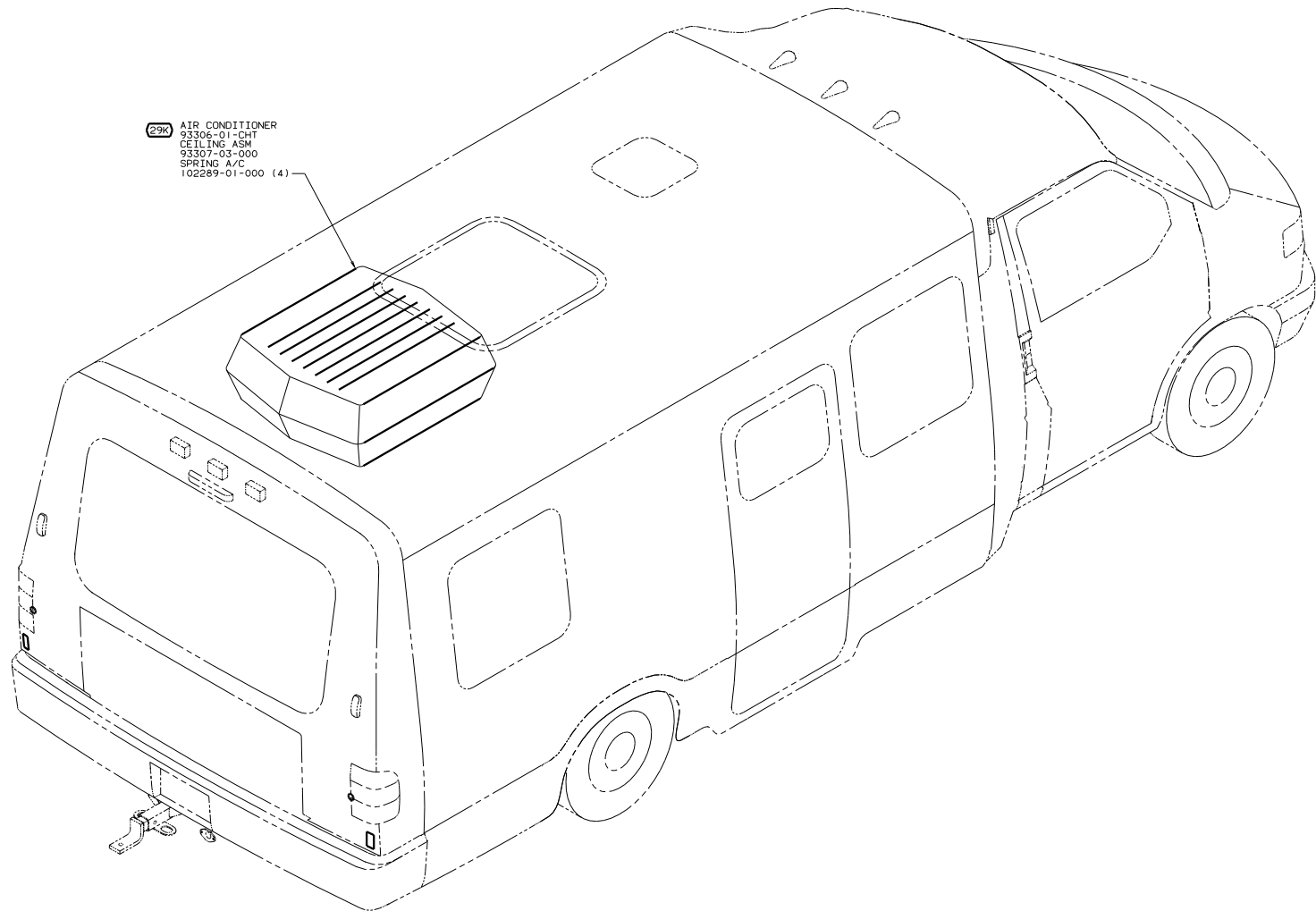

23K AIR CONDITIONER
 93306-01-CHT
 CEILING ASM
 93307-03-000
 SPRING A/C
 102289-01-000 (4)

- 23K** A/C ROOF-ONE 7,100 BTU
- 265** CODES/STANDARDS-CSA/CMVSS
- 1B1** CODES STANDARDS/USA
- 04L** JAPAN EXPORT PACKAGE
- 1B1 265 04L** 00 2220D

FOR ELECTRICAL
 TORQUE
 SPECIFICATIONS
 SEE DWG NO.
 128783-01-000

TITLE: WIRING INSTL-BODY, L10V(EXT)
 SHEET 3 OF 3

NOTES:

