

TYPICAL APPLICATIONS

Multi-fixture RV potable water installations.
Other uses may include 12 VDC pressurized water systems in cabins. This pump may be used for general water transfer. For other applications, contact SHURflo.

PUMP

Type	3 Chamber Diaphragm
Ports	1/2"-14 NPSM-Male
Liquid	130 °F [54 °C] Max
Prime	9 feet [2.7 M]
Inlet PSI	30 PSI [2.1 Bar] Max
Run Dry	Yes

ELECTRICAL

Motor	12VDC Permanent Magnet, Intermittent Duty
Protection	Thermal Overload, Automatic Restart
Leads	16 AWG, 16" [40 cm] Red +, 13" [33 cm] Black -
Fuse	10 Amp Time Delay Recommended
Control	Adjustable Switch with Check Valve
	Shut-Off 45 PSI [3.1 Bar] ± 5 PSI [0.4 Bar]
	Restart 25 PSI [1.8 Bar] ± 5 PSI [0.4 Bar]

MATERIALS

Housing	Polypropylene
Valves	EPDM
Diaphragm	Santoprene
Hardware	Zinc Plated Steel

APPROVALS

c-UL

WARRANTY

2 Year Limited Warranty
See SB-1041 For Full Warranty Details

SHIPPING

Net Weight (Boxed)	5 Lb [2.3Kg] each
Carton Weight	12 each, 52 Lb [24 Kg]
Carton Size	24"L x 18"W x 11"H [61cm x 46cm x 28cm]

RELATED DOCUMENTS

Catalog	MS-030-083
Installation Manual	911-352
Maintenance	911-352
Applications Spec Guide	MS-020-005
Warranty	SB-1041

Aqua King Premium



Parts Kits

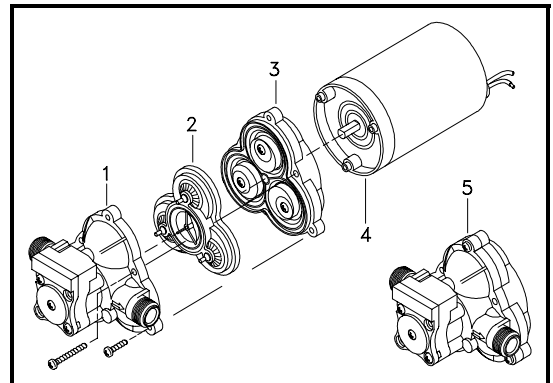

Number	Component	Parts Kit
1	Housing/Switch	94-231-20
2	Valve Assembly	94-232-06
3	Drive Assembly	94-238-04
4	Motor	11-173-01
5	Pump Head	94-236-08
Not Shown	Check Valve	94-237-00

Typical Performance @ 12 VDC

PRESSURE		FLOW		CURRENT
BAR	PSI	GPM	LPM	AMPS
0.0	0	3.5	13.2	3.8
0.7	10	2.6	9.8	4.6
1.4	20	2.2	8.3	4.9
2.1	30	1.7	6.4	5.0
2.8	40	1.0	3.7	4.8

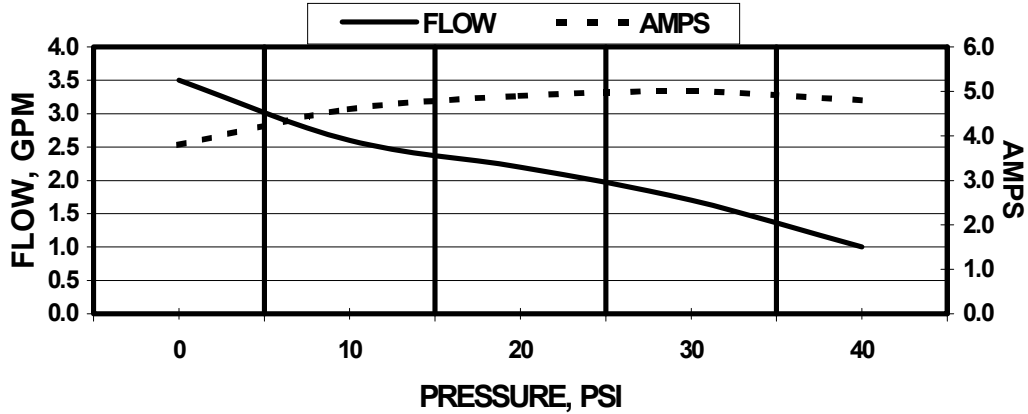

Typical Dimensions

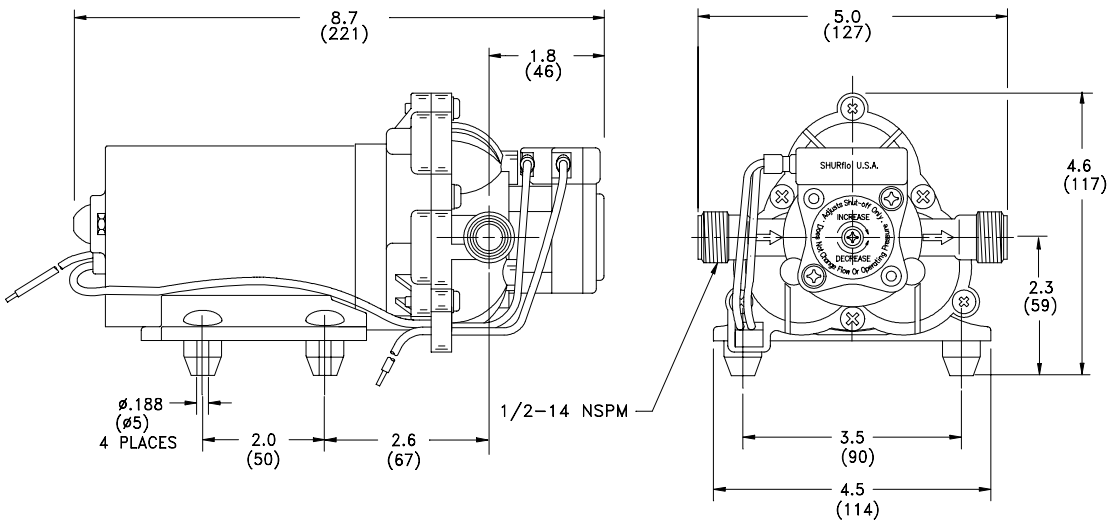

* ISO Registered Facility



First in Fluid Innovation

SHURflo reserves the right to update specifications, prices, or make substitutions.

SHURflo ★
12650 Westminster Ave.
Santa Ana, CA 92706-2100
(800) 854-3218 (714) 554-7709
FAX (714) 554-4721
Shipping/UPS: 12650 Westminster Ave.
Garden Grove, CA 92843

SHURflo East
52748 Park Six Court
Elkhart, IN 46514-5427
((800) 762-8094
(219) 262-0478
FAX (219) 264-2169
© 2001

SHURflo Ltd.
Unit 5 Sterling Park
Gatwick Road, Crawley
West Sussex, RH10 2QT
United Kingdom
+44 1293 424000
FAX +44 1293 421880