

This brief installation guide for SHURflo pump systems will answer the most often encountered questions about basic RV plumbing systems. Additional more detailed information is available through technical data sheets from SHURflo, as well as the installation instruction sheets provided with each product.

For more information, contact your SHURflo representative or SHURflo customer service toll free at:

West of the Rockies: (800) 854-3218

East of the Rockies: (800) 762-8094

Wire Size Requirements <small>[Based on 10 Amps; 10% voltage drop]</small>	
Battery-to-pump distance	Wire
0-10 feet	16 GA
10-30 feet	14 GA
30-40 feet	12 GA
40-50 feet	10 GA

Plumbing Guidelines <small>[For long life and low noise]</small>	
SHURflo Fittings	Hand tighten only
Feet	Snug, don't flatten, solid surface
Pump/Hose	Flexible hose on inlet and outlet side of pump. 1/2" minimum on mains, 3/8" minimum on branch
Water Purifier	Run separate line from mains. 1/4" minimum recommended
Noise Reduction	Use flexible hose. Check for air in system, including all drain lines and hot water heater lines

## Single Fixture Systems

Single fixture installations using the Nautilus™ pump are very straight-forward. The key requirement is that the pumphead be mounted 4" or less above the bottom of the water tank.

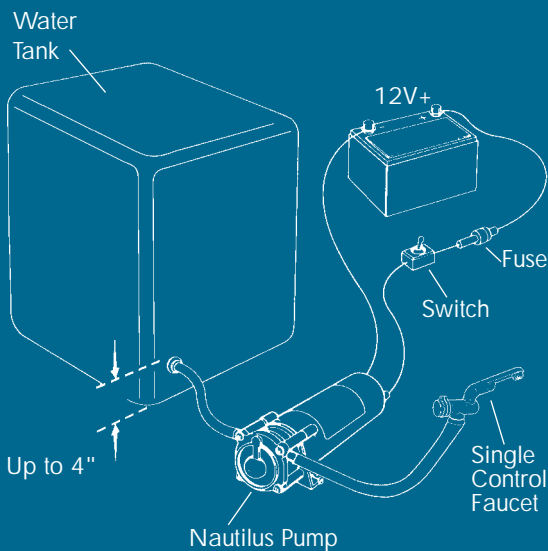

## Potable Water Multi-Fixture Systems

These pumps may be mounted up to six feet above the source. Wiring must include a switch and fuse and/or circuit breaker (Refer to instruction manual provided with each pump). The inlet side of all fresh water pumps should include the use of a SHURflo strainer. Mount the pump in an accessible location for strainer inspection and maintenance.

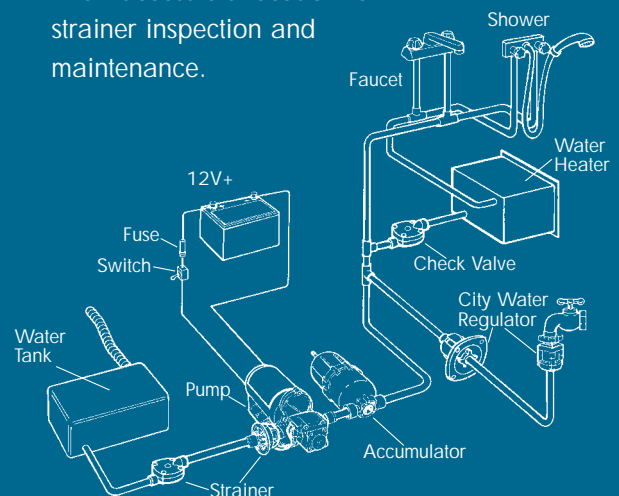

## General Notes

- SHURflo pumps will operate in any position; however, the recommended position is motor up/pumphead down to prevent any possible water damage to the motor in the event of a leak. Mount on a solid surface to reduce noise and vibration.
- SHURflo offers a variety of barbed and threaded fittings in sizes from 3/8" to 3/4" straight and elbow.
- SHURflo requires that all pumps be fused individually in addition to any other circuit protection used such as circuit breakers.
- All SHURflo 2088 & 2093 pump ports are internally tapered, to be hand-tightened only with SHURflo swivel fittings.
- All SHURflo pumps are engineered with rubber mounting feet to minimize noise and vibration and will function properly only if proper fasteners are used to snug down (not flatten) the feet. Flexible mounting, as well as flexible inlet and outlet plumbing (such as reinforced hose), is critical to low pump noise level and pump longevity.
- The self-priming feature of SHURflo diaphragm pumps allows them to be mounted any distance up to 30 feet horizontal from on-board water supplies, insuring easy access to plumbing connections and strainers, maximizing reduction of noise or vibration and minimizing exposure to splashed water.
- Waterguard™ filters are great for RV, Marine and Home applications. The filter may be installed in any convenient location. Be sure to keep the filter away from any heat source. All filters should be replaced seasonally (6-12 months) or when taste and odor problems return.

### Radiator Cooling Systems

Pumphead should be mounted 4" or less above the bottom of the tank. Do not mount in engine compartment, where excess heat can cause the thermal overload device to trip. 3/8" heat resistant hose is recommended.

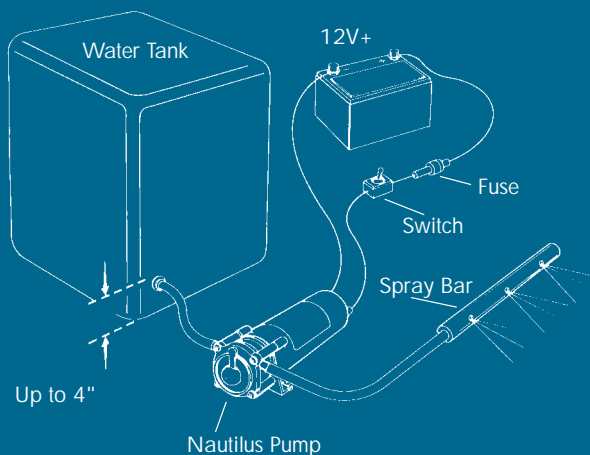

### Shower Sump Systems

The standard 2088 model can be used for shower sump applications. The sump tray should employ a 6"-8" trap with adequate strainer capability. Use a strainer on the inlet side of the pump, mounted in an easy access location for inspection.

