



Important!

Please give copies to all your VW Technicians

Technical Bulletin

Subject: **Side Airbag, On Board Diagnostic (OBD)**

Group: **01**

Number: **00-05**

Model(s): **All**

2000, 2001

Date: **Aug. 22, 2000**

Service

Additional diagnostic procedures have been established to prevent improper replacement of airbag components. In addition, certain airbag wiring harness terminals and connectors can now be repaired using VAS 1978 Wire Harness Repair Kit. Follow all diagnostic procedures in this bulletin and Repair Manual before beginning repair.

Subject	Technical Bulletin Page	Repair Manual Page
- Airbag On Board Diagnostic (OBD)	2	-
- Airbag Diagnostic Trouble Code (DTC) Table	3	-
- Measuring value block, reading	5	-
- Display group 005	7	-
- Evaluating display group 005	8	-
- VAS 5056 test box	15	-
- VAS 5056 test box, components	15	-
- Airbag, connecting test box to side airbag components, example	16	-
- Wire harness, repair	17	-
- Terminal, inspection	18	-

(Cont. on Page 2)



Important!

Please give copies to all your VW Technicians

Technical Bulletin

CAUTION!

ALWAYS review and follow all CAUTIONS and WARNINGS in the Repair Manual regarding Airbags!

Airbag On Board Diagnostic (OBD)

For diagnosis using VAS 5051, see VAS 5051 Tester.

For additional VAG 1551 information, see Repair Manual, *Body On Board Diagnostic (OBD)*, Repair Group 01.

Rapid Data Transfer HELP
Enter address word XX

◀ Indicated on display

Note:

With the address word 00 the automatic test sequence is carried out i.e., the DTC memories of all systems in the vehicle capable of On Board Diagnostic (OBD) are checked via the rapid data transfer.

Press buttons -1- and -5- to insert "Airbag" address word 15.

Rapid Data Transfer Q
15 - Airbag

◀ Indicated on display

– Press -Q- button to confirm input.

1J0 909 608 D AIRBAG VW 3-S V03→
Coding 0068 WSC12345

◀ Indicated on display

– Press → button.

Rapid Data Transfer Q
Select function XX

◀ Indicated on display

(Cont. on Page 3)



Important!

Please give copies to all your VW Technicians

Technical Bulletin

Rapid Data Transfer Q
02 – Check DTC Memory

Press buttons -0- and -2- to select “Check DTC Memory” function 02.

◀ Indicated on display

Press -Q- button to confirm input.

X DTC Recognized

◀ Indicated on display (number of DTCs recognized)

The stored DTCs are displayed and printed out one after the other.

Eliminate DTCs by referencing DTC table. See page 4.

Airbag Diagnostic Trouble Code (DTC) Table

VAG 1551 Scan Tool Display	Possible cause	Corrective Action
01217 Igniter for side airbag, driver's side -N199- Resistance value too large Resistance value too small Short circuit to B+ Short circuit to Ground (GND)	Improper or damaged connection	- Read Measuring Value Block. See page 5.
	Faulty wiring or connections	
	Igniter for side airbag, driver's side -N199- faulty	
01218 Igniter for side airbag, passenger's side -N200- Resistance value too large Resistance value too small Short circuit to B+ Short circuit to Ground (GND)	Improper or damaged connection	- Read Measuring Value Block. See page 5.
	Faulty wiring or connection	
	Igniter for side airbag, passenger's side -N200- faulty	

(Cont. on Page 4)



Important!

Please give copies to all
your VW Technicians

Technical Bulletin

VAG 1551 Scan Tool Display	Possible cause	Corrective Action
01221 Crash sensor for side airbag, driver's side -G179- Resistance value too large Resistance value too small Short circuit Open circuit Faulty Not authorized	Faulty wiring or connections	- Check terminals in both connectors are fully seated. If damaged, repair or replace using VAS 1978 Repair Kit. - Check connectors. If damaged, repair using VAS 1978 Repair Kit.
	Crash sensor faulty Control module faulty	- Replace damaged component.
	Crash sensor and control module do not match	- Replace crash sensor or control module.
01222 Crash sensor for side airbag, passenger's side -G180- Resistance value too large Resistance value too small Short circuit Open circuit Faulty Not authorized	Faulty wiring or connections	- Check terminals in both connectors are fully seated. If damaged, repair or replace using VAS 1978 Repair Kit. - Check connectors. If damaged, repair using VAS 1978 Repair Kit.
	Crash sensor faulty Control module faulty	- Replace damaged component.
	Crash sensor and control module do not match	- Replace crash sensor or control module.
65535 Control module malfunctioning	Electrical interference as a result of external sources, poor Ground (GND) connections or Positive connections to control module -J234-	- Test wiring and connections to control module according to wiring diagram ¹⁾
	Control module -J234- faulty	- Replace control module. ¹⁾

1) Replace control module only if DTC 65535 is displayed or vehicle has been involved in an accident.

(Cont. on Page 5)



Important!

Please give copies to all your VW Technicians

Technical Bulletin

Measuring value block, reading

WARNING!

Check wiring via visual inspection only. Do not check continuity or resistance of airbag igniter circuits.

Only check wiring with ignition switched off.

Rapid data transfer HELP
Select function XX

◀ Indicated on display. If VAG 1551 is still in another function:
– Press buttons -0- and -6- to select “End Output” function.

Rapid data transfer HELP
06 – End output

◀ Indicated on display:
– Press -Q- button to confirm entry.

Rapid Data Transfer HELP
Enter address word XX

◀ Indicated on display
– Press buttons -1- and -5- to insert “Airbag” address word 15.

Rapid Data Transfer Q
15 - Airbag

◀ Indicated on display
– Press -Q- button to confirm input.

1J0 909 608 D AIRBAG VW 3-S V03→
Coding 0068 WSC12345

◀ Indicated on display
– Press → button.

(Cont. on Page 6)



Important!

Please give copies to all your VW Technicians

Technical Bulletin

Rapid data transfer	HELP
Select function XX	

- ◀ Indicated on display.
- Press buttons -0- and -8- to select "Read Measuring Value Block" function.

Rapid data transfer	Q
08 – Read measuring value block	

- ◀ Indicated on display
- Press -Q- button to confirm entry.

Read measured value block
Input display group number XXX

- ◀ Indicated on display
- Press buttons -0-, -0- and -5- to select display group 005 and confirm entry with -Q- button.

Read measured value block	1	→		
	1	2	3	4

- ◀ Indicated on display (1-4 = Display Fields)
- Explanation of individual display fields on display is found in evaluation of display group numbers.
- If displayed values in all display fields are "Correct":
- Press → button.

Note:

To change to another display group, proceed as follows:

Display Group	VAG 1551	VAG 1552
Higher	Press button -3-	Press ↑ button
Lower	Press button -1-	Press ↓ button
Skip	Press button -C-	Press button -C-

(Cont. on Page 7)



Important!

Please give copies to all your VW Technicians

Technical Bulletin

Note:

Check DTC memory after completing "Read Measuring Value Block" function 08.

For additional information, see Repair Manual, *Body On Board Diagnostic (OBD)*, Repair Group 01.

Display group 005

Display group 005				
Read Measuring Value Block 5		→	◀ Indicated on display	
xxxx	xxx	xxx	xxxx	
1	2	3	4	◀ Display field
				Specification
				Not Applicable
				Not Applicable
		Igniter for side airbag, passenger's side -N200-		Correct
		Igniter for side airbag, driver's side -N199-		Correct
				Evaluation
				See Page 8

(Cont. on Page 8)



Important!

Please give copies to all
your VW Technicians

Technical Bulletin

Evaluating display group 005

Display field	Designation	Display contents	Corrective action
1	Igniter for side airbag, driver's side -N199-	Correct	- No malfunctions or DTCs present.
		too small to Ground to Positive	<ul style="list-style-type: none"> - Visually check wiring (for damage) and connectors for correct engagement and tight fit. - While observing display, move seat back and forth, fold seats, (2 door models), move wiring up, down, back and forth in different areas. <p>If display changes from "too small", this indicates wiring repairs are necessary.</p> <p>If display remains on "too small"</p> <ul style="list-style-type: none"> - Separate yellow 3-pin connector from side airbag adapter harness under seat. <p>Display remains on "too small":</p> <ul style="list-style-type: none"> - Repair wiring between control module and 3-pin connector using VAS 1978 Repair Kit. <p>Display changes to "too large":</p> <ul style="list-style-type: none"> - Remove seat (Remember to connect airbag adapter VAS 5094 as directed) See Repair Manual, <i>Body-Interior</i>, Repair Group 72. - Pull back seat back cover. See Repair Manual, <i>Body-Interior</i>, Repair Group 74.

(Cont. on Page 9)



Important!

Please give copies to all
your VW Technicians

Technical Bulletin

Display field	Designation	Display contents	Corrective action
1	Igniter for side airbag, driver's side -N199-	too small to Ground to Positive	<ul style="list-style-type: none">- Temporarily reinstall seat , remove VAS 5094 and reconnect 3-pin connector.- Separate igniter connector -N199- from airbag unit. Display reads "too small": <ul style="list-style-type: none">- Replace adapter harness between igniter and 3-pin connector. Display reads "too large" <ul style="list-style-type: none">- Reconnect igniter connector. Display reads "too small": <ul style="list-style-type: none">- Replace airbag unit and adapter harness (if harness has not already been replaced in previous steps).

(Cont. on Page 10)



Important!

Please give copies to all your VW Technicians

Technical Bulletin

Display field	Designation	Display contents	Corrective action
1	Igniter for side airbag, driver's side -N199-	too large to Ground to positive	<ul style="list-style-type: none"> - Visually check wiring (for damage) and connectors for correct engagement and tight fit. - While observing display, move seat back and forth, fold seats, (2 door models), move wiring up, down, back and forth in different areas. <p>If display changes from "too large" this indicates wiring repairs are necessary.</p> <p>If display remains on "too large":</p> <ul style="list-style-type: none"> - Separate 3-pin yellow connector from side airbag adapter harness under seat (Display should remain "too large"). - Connect inert igniter #2 on VAS 5056 (see Page 16 to 3-pin yellow connector). <p>Display should change to "correct":</p> <p>Display remains on "too large":</p> <ul style="list-style-type: none"> - Press button on VAS 5056 to simulate short circuit. <p>Display remains on "too large":</p> <ul style="list-style-type: none"> - Repair wiring between control module and 3-pin connector using VAS 1978 Repair Kit.

(Cont. on Page 11)



Important!

Please give copies to all your VW Technicians

Technical Bulletin

Display field	Designation	Display contents	Corrective action
1	Igniter for side airbag, driver's side -N199-	too large	<p>Display changes to "too small":</p> <ul style="list-style-type: none"> - Remove VAS 5056, remove seat. Remember to connect airbag adapter VAS 5094 as directed. See Repair Manual, <i>Body-Interior</i>, Repair Group 72. - Pull back seat cover. See Repair Manual, <i>Body-Interior</i>, Repair Group 74. - Temporarily reinstall seat, remove VAS 5094 and reconnect 3-pin connector. - Separate igniter connector -N199- from airbag unit. - Bridge ignitor connector -N199- ON ADAPTER WIRE HARNESS with small gauge wire. <p>Display changes to "too small":</p> <ul style="list-style-type: none"> - Replace airbag unit and adapter harness. <p>Display remains on "too large":</p> <ul style="list-style-type: none"> - Remove wire bridge from adapter harness. - Check adapter harness and connectors for damage, i.e., kinked or pinched wire near tie-wrap. - Replace adapter harness between igniter and 3-pin connector. - Reconnect igniter connector. <p>Display remains on "too large":</p> <ul style="list-style-type: none"> - Replace airbag unit and adapter harness (if not previously replaced).

(Cont. on Page 12)



Important!

Please give copies to all your VW Technicians

Technical Bulletin

Display field	Designation	Display contents	Corrective action
2	Igniter for side airbag, driver's side -N200-	Correct	- No malfunctions or DTCs present.
		too small to Ground to Positive	<ul style="list-style-type: none"> - Visually check wiring (for damage) and connectors for correct engagement and tight fit. - While observing display, move seat back and forth, fold seats, (2 door models), move wiring up, down, back and forth in different areas. <p>If display changes from "too small", this indicates wiring repairs are necessary.</p> <p>If display remains on "too small"</p> <ul style="list-style-type: none"> - Separate yellow 3-pin connector from side airbag adapter harness under seat. <p>Display remains on "too small":</p> <ul style="list-style-type: none"> - Repair wiring between control module and 3-pin connector using VAS 1978 Repair Kit. <p>Display changes to "too large":</p> <ul style="list-style-type: none"> - Remove seat (Remember to connect airbag adapter VAS 5094 as directed) See Repair Manual, <i>Body-Interior</i>, Repair Group 72. - Pull back seat back cover. See Repair Manual, <i>Body-Interior</i>, Repair Group 74.

(Cont. on Page 13)



Important!

Please give copies to all your VW Technicians

Technical Bulletin

Display field	Designation	Display contents	Corrective action
2	Igniter for side airbag, driver's side -N200-	too large to Ground to positive	<ul style="list-style-type: none"> - Visually check wiring (for damage) and connectors for correct engagement and tight fit. - While observing display, move seat back and forth, fold seats, (2 door models), move wiring up, down, back and forth in different areas. <p>If display changes from "too large" this indicates wiring repairs are necessary.</p> <p>If display remains on "too large":</p> <ul style="list-style-type: none"> - Separate 3-pin yellow connector from side airbag adapter harness under seat (Display should remain "too large"). - Connect inert igniter #2 on VAS 5056 (see page 16) to 3-pin yellow connector. <p>Display should change to "correct":</p> <p>Display remains on "too large":</p> <ul style="list-style-type: none"> - Press button on VAS 5056 to simulate short circuit. <p>Display remains on "too large":</p> <ul style="list-style-type: none"> - Repair wiring between control module and 3-pin connector using VAS 1978 Repair Kit.

(Cont. on Page 14)



Important!

Please give copies to all your VW Technicians

Technical Bulletin

Display field	Designation	Display contents	Corrective action
2	Igniter for side airbag, driver's side -N200-	too large	<p>Display changes to "too small":</p> <ul style="list-style-type: none"> - Remove VAS 5056, remove seat. Remember to connect airbag adapter VAS 5094 as directed. See Repair Manual, <i>Body-Interior</i>, Repair Group 72. - Pull back seat cover. See Repair Manual, <i>Body-Interior</i>, Repair Group 74. - Temporarily reinstall seat, remove VAS 5094 and reconnect 3-pin connector. - Separate igniter connector -N200- from airbag unit. - Bridge ignitor connector -N200- ON ADAPTER WIRE HARNESS with small gauge wire. <p>Display changes to "too small":</p> <ul style="list-style-type: none"> - Replace airbag unit and adapter harness. <p>Display remains on "too large":</p> <ul style="list-style-type: none"> - Remove wire bridge from adapter harness. - Check adapter harness and connectors for damage, i.e., kinked or pinched wire near tie-wrap. - Replace adapter harness between igniter and 3-pin connector. - Reconnect igniter connector. <p>Display remains on "too large":</p> <ul style="list-style-type: none"> - Replace airbag unit and adapter harness (if not previously replaced).
3	Not applicable	Correct	
4	Not applicable	Correct	

(Cont. on Page 15)



Important!

Please give copies to all your VW Technicians

Technical Bulletin

VAS 5056 test box

It is possible to use VAS 5056 in conjunction with VAG 1551/1552 or VAS 5051 to diagnose airbag system faults.

WARNING!

Check wiring via visual inspection only. Do not check continuity or resistance of airbag igniter circuits.

Only check wiring with ignition switched off.

VAS 5056 test box, components

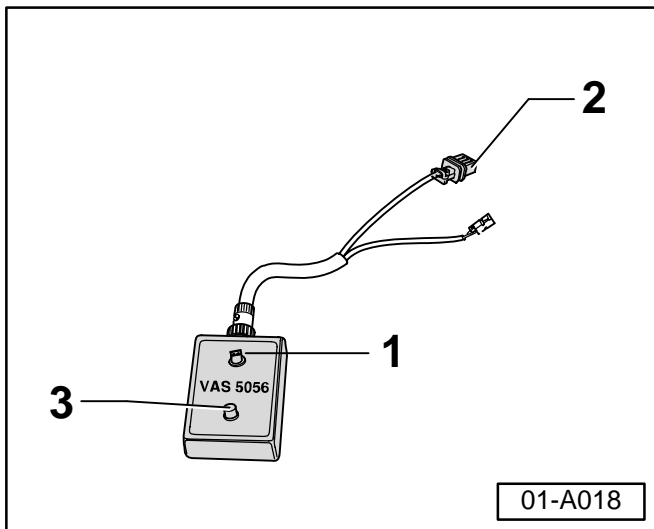

- 1 - Igniter connector on inert igniter #1.
 - Used to simulate correct resistance of igniter at airbag or seat belt.
- 2 - Adapter harness with connectors for inert igniter #2 (VAS 5056/2).
 - Used to connect inert igniter #2 to airbag harness
- 3 - Button
 - Used to simulate short circuit in harness through connectors.

(Cont. on Page 16)



Important!

Please give copies to all your VW Technicians

Technical Bulletin

Airbag, connecting test box to side airbag components, example

- Connect adapter harness with connectors for inert igniter #2 (VAS 5056/2) to airbag harness connector underneath seat. See Evaluating display group 005 for specific diagnostic instructions. If diagnosis is not completed, proceed to next step.
- Press button to simulate short circuit in airbag harness through connectors. Repair as directed. If diagnosis is not completed, proceed to next step.
- Remove seat -1-.

Note:

When removing seat, always connect airbag adapter VAS 5094 as directed. See Repair Manual, Body-Interior, Repair Group 72.

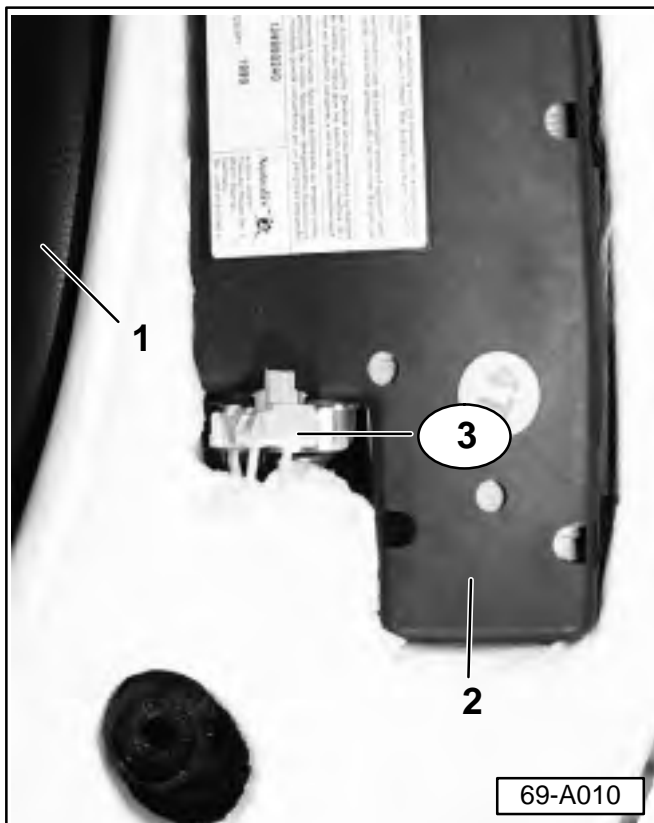

- ◀ - Pull back seatback cover to expose side airbag unit -2-. See Repair Manual, Body-Interior, Repair Group 74.
- Remove connector -3- from airbag igniter.
- Check airbag igniter connector -3- for damage.
- Temporarily reinstall seat, remove VAS 5094 and reconnect 3-pin connector.
- Bridge ignitor connector -N199- or -N200- ON ADAPTER WIRE HARNESS with small gauge wire.
- If concern still exists, replace side air bag unit -2- and adapter harness. See Repair Manual, Body-Interior, Repair Group 69.

(Cont. on Page 17)



Important!

Please give copies to all
your VW Technicians

Technical Bulletin

Wire harness, repair

Note:

No other procedure or materials, other than those in VAS 1978, may be used for wire harness repairs, specifically soldering, wire nuts, generic repair kits, etc.

Always review Safety Precautions in the VAS 1978 Instruction Manual prior to performing any wiring harness repairs.

CAUTION!

Wiring that is part of the ABS system and shielded wiring for components, such as speed sensors or knock sensors, may not be repaired, but must ALWAYS be replaced.

DO NOT use solder wire when repairing a wiring harness.

Only use approved methods and materials if wiring harness repairs are required.

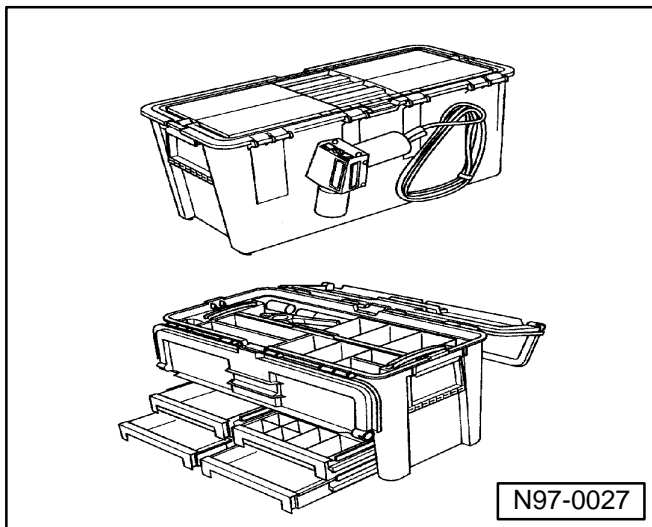

If wiring harness repairs are required:

- ◀ – Use only VAS 1978 Wire Harness Repair Kit.
- If wire harness cannot be repaired using this procedure and materials contained in VAS 1978, replace wire harness.



Important!

Please give copies to all
your VW Technicians

Technical Bulletin

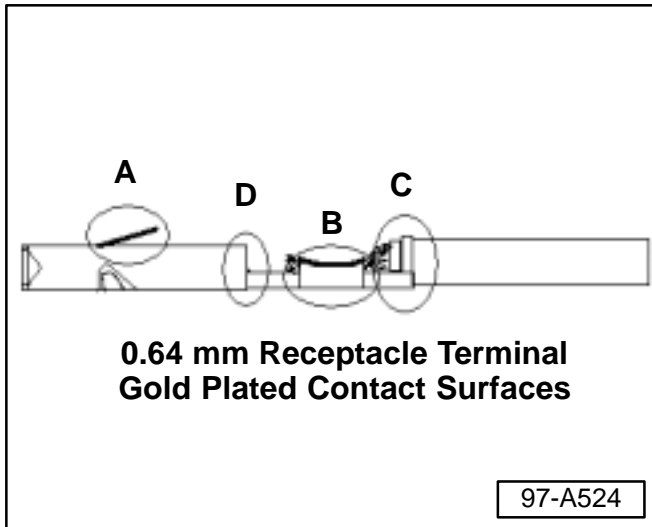

Terminal, inspection

◀ Replace terminal when one of following conditions occur:

Terminal is bent or unintentionally deformed.

Terminal is cracked or torn at crimped areas -B- and -C-.

Wire insulation has been drawn into core crimp -B-.

Material is cracked at transition bend -D-.

Terminal coating shows signs of moisture or "greasy" coating. Terminal surface should be bright and shiny.

Primary lock tab(s) -A- should be straight and stand away from terminal.

Note:

During terminal extraction, primary lock tab(s) may have been pressed into terminal. Straighten using sharp edge to carefully lift tab.