

Onan

RV GenSet

Operator's Manual

KVC



Printed in U.S.A.

981-0158C
10-01



WARNING:



The engine exhaust from this product contains chemicals known to the State of California to cause cancer, birth defects or other reproductive harm.



WARNING



**Do not use this genset on a boat
Such use may violate U. S. Coast Guard
regulations and can result in
severe personal injury or death from
fire, electrocution, or
carbon monoxide poisoning**

Table of Contents

SAFETY PRECAUTIONS	2
INTRODUCTION	4
About this Manual	4
Nameplate	4
Typical Genset	5
Fuel Recommendations	6
Engine Oil Recommendations	6
Starting Batteries	6
Genset Control Panel	7
Remote Control Panel	7
OPERATION	8
Conducting the Pre-Start Checks	8
Starting the Genset	8
Stopping the Genset	9
Restarting the Genset	9
Loading the Genset	9
Resetting Circuit Breakers	10
Connecting to Utility Power	10
Operating in Cold Weather	11
Operating in Hot Weather	11
Operating at High Altitude	11
Operating in Dusty Environments	12
Breaking in a New Engine	12
Exercising the Genset	12
Storing the Genset	12
PERIODIC MAINTENANCE	14
Conducting General Inspections	15
Checking Engine Oil Level	16
Changing Engine Oil	17
Replacing the Air Filter Element	18
Maintaining the Battery and Battery Connections	18
Replacing the Spark Plug	19
Cleaning the Spark Arrestor	19
Replacing the Fuel Filter	20
TROUBLESHOOTING	21
SPECIFICATIONS	22
INFORMATION FOR CALIFORNIA GENSET USERS	23
HOW TO OBTAIN SERVICE	24
MAINTENANCE RECORD	25

Safety Precautions

Thoroughly read the **OPERATOR'S MANUAL** before operating the genset. Safe operation and top performance can be obtained only when equipment is operated and maintained properly.

The following symbols in this manual alert you to potential hazards to the operator, service person and equipment.

⚠ DANGER alerts you to an immediate hazard which will result in severe personal injury or death.

⚠ WARNING alerts you to a hazard or unsafe practice which can result in severe personal injury or death.

⚠ CAUTION alerts you to a hazard or unsafe practice which can result in personal injury or equipment damage.

Electricity, fuel, exhaust, moving parts and batteries present hazards which can result in severe personal injury or death.

GENERAL PRECAUTIONS

- Keep children away from the genset.
- Do not use evaporative starting fluids. They are highly explosive.
- To prevent accidental or remote starting while working on the genset, disconnect the negative (-) battery cable at the battery.
- Keep the genset and its compartment clean. Excess oil and oily rags can catch fire. Dirt and gear stowed in the compartment can restrict cooling air.
- Make sure all fasteners are secure and torqued properly.
- Do not work on the genset when mentally or physically fatigued or after consuming alcohol or drugs.

- You must be trained and experienced to make adjustments while the genset is running—hot, moving or electrically live parts can cause severe personal injury or death.
- Used engine oil has been identified by some state and federal agencies as causing cancer or reproductive toxicity. Do not ingest, inhale, or contact used oil or its vapors.
- Benzene and lead in some gasolines have been identified by some state and federal agencies as causing cancer or reproductive toxicity. Do not to ingest, inhale or contact gasoline or its vapors.
- Keep multi-class ABC fire extinguishers handy. Class A fires involve ordinary combustible materials such as wood and cloth; Class B fires, combustible and flammable liquid fuels and gaseous fuels; Class C fires, live electrical equipment. (ref. NFPA No. 10)
- Genset installation and operation must comply with all applicable local, state and federal codes and regulations.

GENERATOR VOLTAGE IS DEADLY!

- Generator electrical output connections must be made by a trained and experienced electrician in accordance with applicable codes.
- The genset must not be connected to shore power or to any other source of electrical power. Back-feed to shore power can cause electric shock resulting in severe personal injury or death and damage to equipment. An approved switching device must be used to prevent interconnections.
- Use caution when working on live electrical equipment. Remove jewelry, make sure clothing and shoes are dry, stand on a dry wooden platform or rubber insulating mat and use tools with insulated handles.

ENGINE EXHAUST IS DEADLY!

- Learn the symptoms of carbon monoxide poisoning in this manual and never sleep in the vehicle while the genset is running unless the vehicle is equipped with a working carbon monoxide detector.
- The exhaust system must be installed in accordance with the genset Installation Manual. Engine cooling air must not be used for heating the working or living space or compartment.
- Inspect for exhaust leaks at every startup and after every eight hours of running.
- Make sure there is ample fresh air when operating the genset in a confined area.

FUEL IS FLAMMABLE AND EXPLOSIVE

- Do not smoke or turn electrical switches ON or OFF where fuel fumes are present or in areas sharing ventilation with fuel tanks or equipment. Keep flame, sparks, pilot lights, arc-producing equipment and switches and all other sources of ignition well away.
- Fuel lines must be secured, free of leaks and separated or shielded from electrical wiring.

- Leaks can lead to explosive accumulations of gas. Natural gas rises when released and can accumulate under hoods and inside housings and buildings. LPG sinks when released and can accumulate inside housings and basements and other below-grade spaces. Prevent leaks and the accumulation of gas.

BATTERY GAS IS EXPLOSIVE

- Wear safety glasses.
- Do not smoke.
- To reduce arcing when disconnecting or reconnecting battery cables, always disconnect the negative (-) battery cable first and reconnect it last.

MOVING PARTS CAN CAUSE SEVERE PERSONAL INJURY OR DEATH

- Do not wear loose clothing or jewelry near moving parts such as PTO shafts, fans, belts and pulleys.
- Keep hands away from moving parts.
- Keep guards in place over fans, belts, pulleys, and other moving parts.

Introduction

ABOUT THIS MANUAL

This manual covers the operation and maintenance of the KVC series of generator sets (gensets). Each operator should study this manual carefully and observe all of its instructions and safety precautions. Keep this manual and the Installation Manual with the other vehicle manuals.

Operation, Periodic Maintenance and Troubleshooting provide the instructions necessary for operating the genset and maintaining it at top performance. The owner is responsible for performing maintenance in accordance with the PERIODIC MAINTENANCE SCHEDULE (Page 14). This manual also includes genset specifications, information on how to obtain service and information for California users.

⚠WARNING *This genset is not a life support system. It can stop without warning. Children, persons with physical or mental limitations, and pets could suffer personal injury or death. A personal attendant, redundant power or an alarm system must be used if genset operation is critical.*

NAMEPLATE

Model and Serial Numbers: Have the model and serial numbers handy (gray boxes, Figure 1) when contacting an Onan dealer for parts, service or product information. Each character is significant. (The last character of the model number is the specification letter, which is important for obtaining the right parts.) Record these numbers in the boxes in Figure 1 so that they are handy when you need them.

Genuine Onan replacement parts are recommended for best performance and safety.

Federal Emissions Compliance Period: The Federal Emissions Compliance Period referred to on the nameplate indicates the number of operating hours for which the engine has been shown to meet Federal emissions requirements. Category C = 250 hrs, B = 500 hrs, A = 1000 hrs.

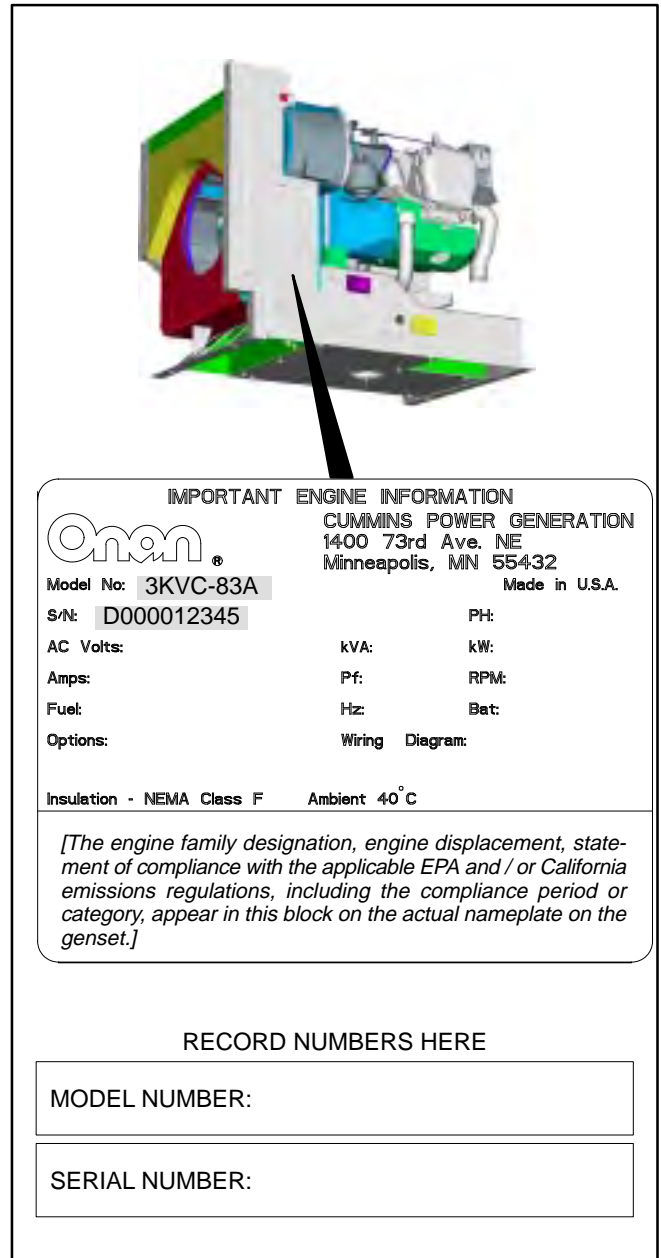

FIGURE 1. TYPICAL NAMEPLATE

TYPICAL GENSET

Figure 2 illustrates a typical genset showing the locations requiring access for operation and periodic maintenance. For clarity, the genset compartment door and front panels (provided by the vehicle manufacturer) are not shown.

⚠WARNING *Operating the genset with the compartment door off can lead to severe burns and engine damage due to overheating. Always secure the door after starting the genset.*

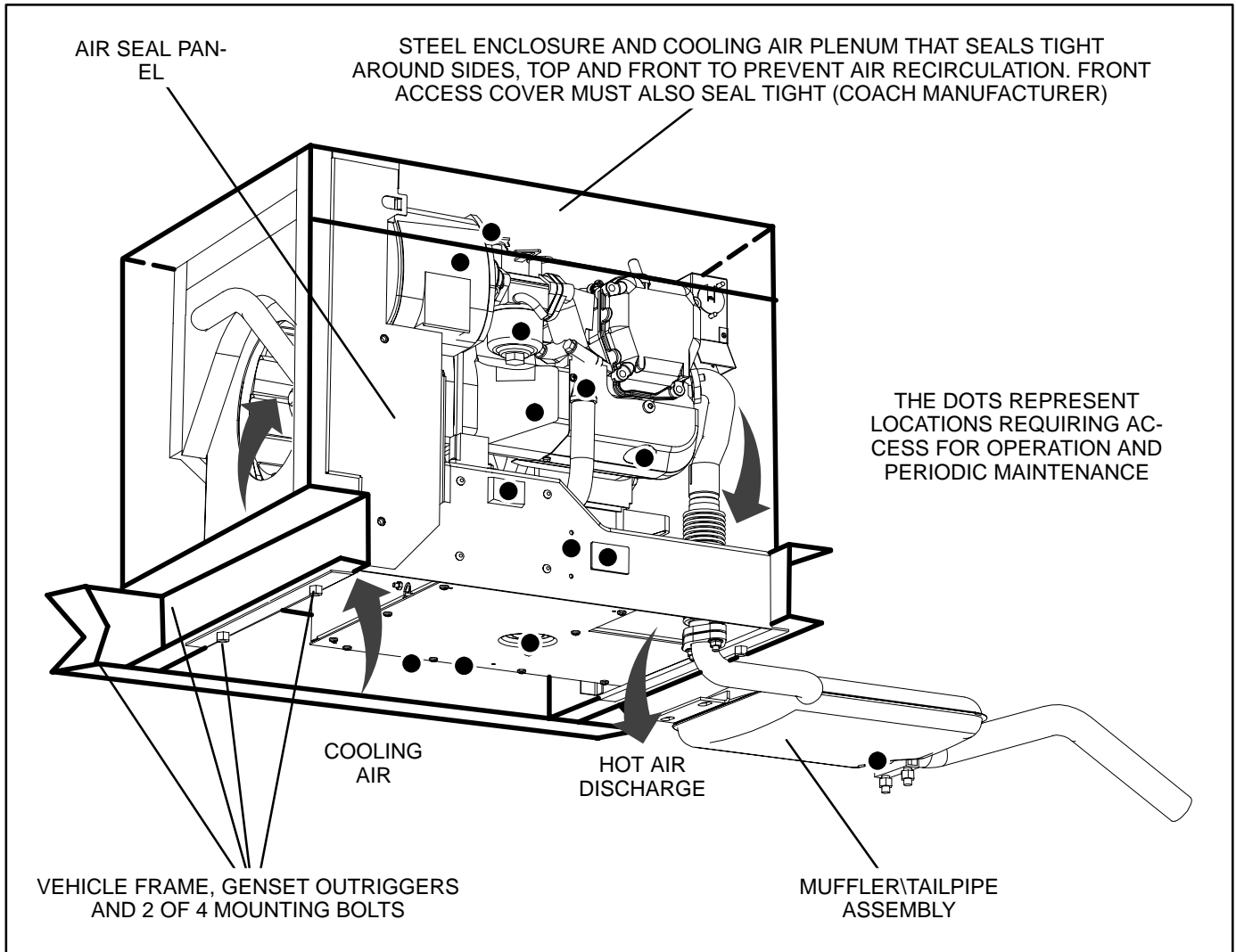

FIGURE 2. TYPICAL GENSET

FUEL RECOMMENDATIONS

⚠ WARNING *Gasoline is highly flammable and explosive and can cause severe personal injury or death. Do not smoke or turn electrical switches ON or OFF where fuel fumes, tanks or equipment are present or in areas sharing ventilation. Keep flame, sparks, pilot lights, arc-producing equipment and switches and all other sources of ignition well away. Keep a type ABC fire extinguisher in the vehicle.*

Use clean, fresh unleaded gasoline having a minimum octane rating (Anti-Knock Index) of 87.

Leaded gasoline may be used but will result in the extra maintenance required for removing combustion chamber and spark plug deposits. Do not use gasoline or gasoline additives (de-icers) containing methanol because methanol can be corrosive to fuel system components.

⚠ CAUTION *Do not use gasoline or gasoline additives containing methanol because methanol can be corrosive to fuel system components.*

Avoid using highly leaded gasolines and lead additives because of the extra engine maintenance that will be required.

ENGINE OIL RECOMMENDATIONS

Use API (American Petroleum Institute) performance Class **SJ**, **SH** or **SG** engine oil, which may be in combination with performance Class CH-4, CG-4 or CF-4 (for example: SJ/CH-4). Also look for the SAE (Society of Automotive Engineers) viscosity grade. Referring to Table 1, choose the viscosity

grade appropriate for the ambient temperatures expected until the next scheduled oil change.

Single-grade SAE 30 oil is preferable when temperatures are consistently above freezing. Multigrade oils are better when wide temperature variations are expected.

TABLE 1. OIL VISCOSITY VS. TEMPERATURE

EXPECTED AMBIENT TEMPERATURES	SAE VISCOSITY GRADE
32° F (0° C) and higher	30
10° F to 100° F (-12° C to 38° C)	15W-40 (OnaMax™)
0° F to 80° F (-18° C to 27° C)	10W-30 10W-40
-20° F to 50° F (-28° C to 10° C)	5W-30

STARTING BATTERIES

The genset has a 12 volt, direct current (DC) engine cranking and control system. Usually the same set of batteries is used for all DC vehicle loads, including vehicle lighting and genset cranking. These batteries are recharged by an AC-powered DC converter/battery charger system in the vehicle. (50 Hz gensets have a regulated 10 ampere battery charging system.)

See *Specifications* (Page 22) regarding minimum battery ratings for reliable genset cranking, especially in cold weather. Also see PERIODIC MAINTENANCE SCHEDULE (Page 14) and the battery manufacturer's instructions regarding maintenance. Reliable genset starting and starter service life depend upon adequate battery system capacity and proper maintenance.

GENSET CONTROL PANEL

The genset control panel (Figure 3) includes the following features:

Control Switch - This is a rocker switch which returns to its neutral position when you let go. Hold the switch in its **START** position to crank and start the genset. Press the switch to its **STOP** position to stop the genset.

Line Circuit Breaker - The line circuit breaker protects the AC power leads connected to the genset from overloads and equipment short circuits.

Hour Meter - The hour meter records genset running time in hours. It cannot be reset. See the PERIODIC MAINTENANCE SCHEDULE (Page 14).

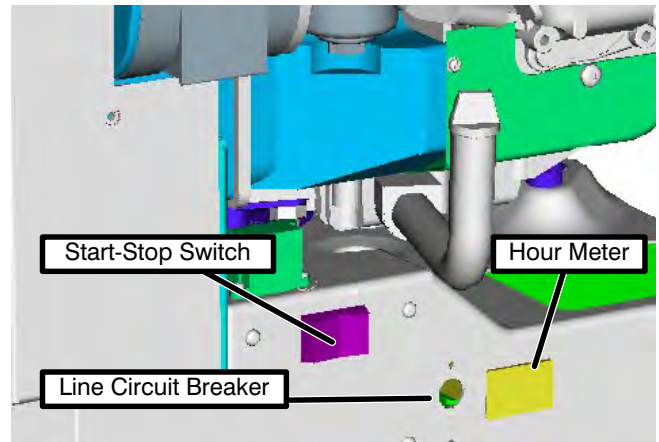

FIGURE 3. GENSET CONTROL PANEL

REMOTE CONTROL PANEL

The vehicle probably has a control panel inside the vehicle for remote control of the genset. Onan offers three remote control kits as follows:

- Remote switch with indicator lamp only (Figure 4).
- Remote switch with indicator lamp and hour meter (Figure 5).
- Remote switch with indicator lamp and DC voltmeter (Figure 6).

The hour meter (time totalizing meter) records genset operating time in hours. It cannot be reset. See the PERIODIC MAINTENANCE SCHEDULE (Page 14).

The DC voltmeter indicates whether voltage across the 12 VDC control system and battery is normal. If the indicator consistently stays above or below the normal zone, see MAINTAINING THE BATTERY AND BATTERY CONNECTIONS (Page 18).

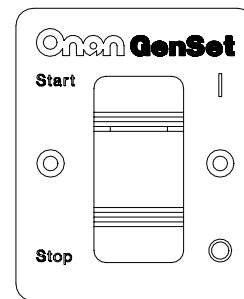

FIGURE 4. REMOTE START/STOP

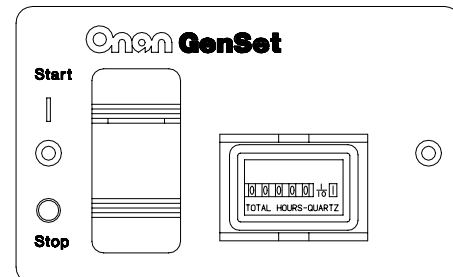

FIGURE 5. REMOTE START/STOP, HOUR METER

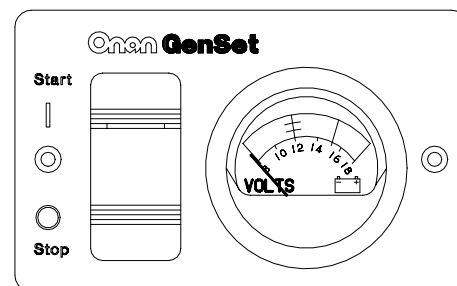

FIGURE 6. REMOTE START/STOP, DC VOLTMETER

Operation

⚠ WARNING EXHAUST GAS IS DEADLY!

Exhaust gases contain carbon monoxide, an odorless, colorless gas. Carbon monoxide is poisonous and can cause unconsciousness and death. Symptoms of carbon monoxide poisoning include:

- *Dizziness*
- *Muscular Twitching*
- *Weakness and Sleepiness*
- *Throbbing in Temples*
- *Headache*
- *Inability to Think Clearly*
- *Nausea*
- *Vomiting*

IF YOU OR ANYONE ELSE EXPERIENCES ANY OF THESE SYMPTOMS, GET OUT INTO THE FRESH AIR IMMEDIATELY. If symptoms persist, seek medical attention. Shut down the genset and do not operate it until it has been inspected and repaired.

Never sleep in the vehicle with the genset running unless the vehicle is equipped with a working carbon monoxide detector. Primary protection against inhaling carbon monoxide, however, is proper installation of the exhaust system, daily (every eight hour) inspection for visible and audible exhaust system leaks.

CONDUCTING THE PRE-START CHECKS

Before the first start of the day and after every eight hours of operation, inspect the genset as instructed under CONDUCTING GENERAL INSPECTIONS (Page 15). Keep a log of maintenance and the hours run and perform any maintenance that may be due. See Returning the Genset to Service (Page 13) if the vehicle has been in storage.

Before each start:

1. Make sure all vehicle CO detectors are working.
2. Check for signs of fuel and exhaust leaks and for damage to the exhaust system.
3. To prevent overheating and to reduce fouling with dust and debris, make sure the genset's normal ground clearance is not being reduced by sloping ground, curbs, logs or other objects. Repark the vehicle if necessary and/or remove any objects blocking the air inlet or air outlet.
4. Turn off the air conditioner and other large appliances.

STARTING THE GENSET

Start the genset from the genset control panel or remote control panel inside the vehicle (Page 7).

1. Push and hold the switch at **START** until the genset starts. (The remote START switch inside the vehicle should have a lamp which lights to indicate that the genset has started and is running.)

⚠ CAUTION Cranking for longer than 10 seconds at a time can overheat and damage the starter. Do not crank for more than 10 seconds at a time and wait at least 30 seconds before trying again.

2. For top performance and engine life, especially in colder weather, let the engine warm up for two minutes before connecting appliances.
3. Check for fuel and exhaust leaks. Stop the genset immediately if there is a fuel or exhaust leak and have it repaired.
4. See *Troubleshooting* (Page 21) if the engine does not crank or start after several tries.
5. Always secure the genset compartment door after starting the genset at the genset control panel.

⚠ WARNING Operating the genset with the compartment door off can lead to severe burns and engine damage due to overheating. Always secure the door after starting the genset.

STOPPING THE GENSET

Turn off the air conditioner and other large appliances and let the genset run for two minutes to cool down. This reduces backfiring and run-on. Then press the switch to **STOP** to stop the genset.

RESTARTING THE GENSET

If the genset shuts down, disconnect or turn off as many appliances as possible and try restarting the genset. Reconnect only as many appliances as will not overload the genset or cause the circuit breaker to trip.

LOADING THE GENSET

The genset can power AC motors, air conditioners, AC/DC converters and other appliances. How much appliance load* can be serviced depends upon the genset power rating. The genset will shut down or its circuit breakers will trip if the sum of the loads exceeds genset power.

To avoid overloading the genset and causing shut-downs, compare the sum of the loads of the appliances that are likely to be used at the same time to the power rating of the genset. Use Table 2 or the ratings on the appliances themselves (if so marked) to obtain the individual appliance loads. ***It may be necessary to run fewer appliances at the same time—the sum of the loads must not be greater than genset rating.***

Note that the genset may shut down due to overload—even though the sum of the loads is less than genset rating—when a large motor or air conditioner is started last or cycles off and then on again. The reason for this is that motor startup load is much larger than running load. ***It may be necessary to run fewer appliances when large motors and air conditioners are cycling on and off.***

TABLE 2. TYPICAL APPLIANCE LOADS

Appliance	Load (watts)
Air Conditioner	1400-2000
Battery Charger	Up to 800
DC Converter	300-500
Refrigerator	600-1000
Microwave Oven	1000-1500
Electric Frying Pan or Wok	1000-1500
Electric Stove Element	350-1000
Electric Water Heater	1000-1500
Electric Iron	500-1200
Electric Hair Dryer	800-1500
Coffee Percolator	550-750
Television	200-600
Radio	50-200
Electric Drill	250-750
Electric Broom	200-500
Electric Blanket	50-200

Note also that air density decreases as altitude increases, causing genset engine power to decrease.** Power decreases approximately 3.5 percent of rated power each 1000 feet (305 m) of increase in elevation. See Table 3 for typical calculations. ***It may be necessary to run fewer appliances at higher altitudes.***

TABLE 3. POWER VS. ALTITUDE

Elevation above Mean Sea Level	Maximum Genset Power*
up to 500 feet (152 m)	2800 watts (rated)
2500 ft (762 m)	2604 watts
5500 ft (1676 m)	2310 watts
above 5500 ft (1676 m)	2310 watts minus 98 watts each 1000 ft (305 m)

* This table does not take into account the effect circuit breakers may have in limiting maximum power.

* Appliance load and genset power are measured in terms of watts (W) or kilowatts (kW), where 1 kilowatt (kW) = 1000 watts (W).

** Power decreases even though the altitude adjust knob is set correctly (Page 11).

RESETTING CIRCUIT BREAKERS

If a circuit breaker in the main power distribution panel of the vehicle or on the genset (Figure 7) trips, either a circuit shorted or too many appliances were running. Note that the genset will continue to run after a circuit breaker trips.

If a circuit breaker trips, disconnect or turn off as many loads as possible and reset the circuit breaker. (Push the circuit breaker to **OFF** to reset it and then to **ON** to reconnect the circuit.) If the circuit breaker trips right away, either the electrical distribution system has a short or the circuit breaker is faulty. Call a qualified electrician.

If the circuit breaker does not trip, reconnect the appliances, one by one, up to a total load that does not overload the genset or cause the circuit breaker to trip. If a circuit breaker trips right away when an appliance is connected, the appliance probably has a short.

Electrical appliances and tools must be used and maintained properly and be properly grounded to cause the line circuit breakers to trip when short circuits occur.

⚠WARNING *Short circuits in electrical appliances and tools can cause fire and electrical shock leading to severe personal injury or death. Read and follow the equipment and tool manufacturer's instructions and warnings regarding use, maintenance and proper grounding.*

CONNECTING TO UTILITY POWER

A vehicle with provisions for connecting utility power must have an approved device to keep the genset and utility from being interconnected. See the genset Installation Manual for more information.

⚠WARNING *Interconnecting the genset and the public utility (or any other power source) can lead to electrocution of utility line workers, equipment damage and fire. Use an approved switching device to prevent interconnections.*

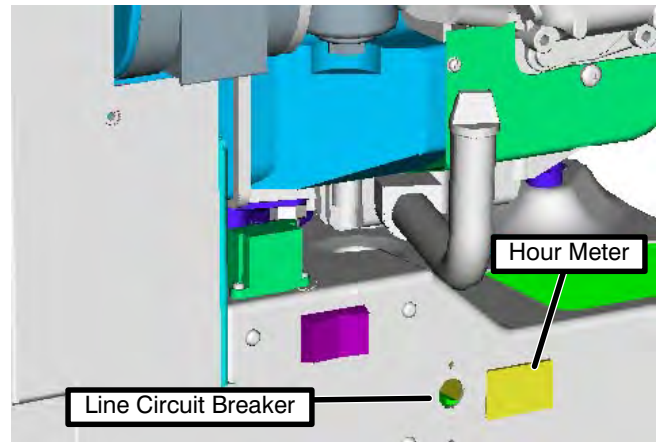

FIGURE 7. LINE CIRCUIT BREAKER

OPERATING IN COLD WEATHER

Pay particular attention to the following items when operating the genset in cold weather:

1. Make sure engine oil viscosity is appropriate for the ambient temperatures. Change oil if there is a sudden drop in temperature. See ENGINE OIL RECOMMENDATIONS (Page 6).
2. Reset the carburetor for altitude (Figure 8).
3. Perform spark plug maintenance (Page 19).
4. Perform battery maintenance (Page 18).

OPERATING IN HOT WEATHER

Pay particular attention to the following items when operating the genset in hot weather:

1. Make sure nothing blocks the airflow to and from the set.
2. Make sure engine oil viscosity is appropriate for the ambient temperatures. See ENGINE OIL RECOMMENDATIONS (Page 6).
3. Keep the genset clean.
4. Perform maintenance due. See PERIODIC MAINTENANCE SCHEDULE (Page 14).
5. Reset the carburetor for altitude (Figure 8).

OPERATING AT HIGH ALTITUDE

For best fuel economy and genset operation reset the carburetor for the current altitude (Figure 8). Look at road maps and road signs. For the effect of altitude on maximum power, see LOADING THE GENSET (Page 9).

CAUTION *Operating the genset at low altitude with a high altitude setting can cause power loss, overheating and engine damage. Always reset when returning to lower altitudes.*

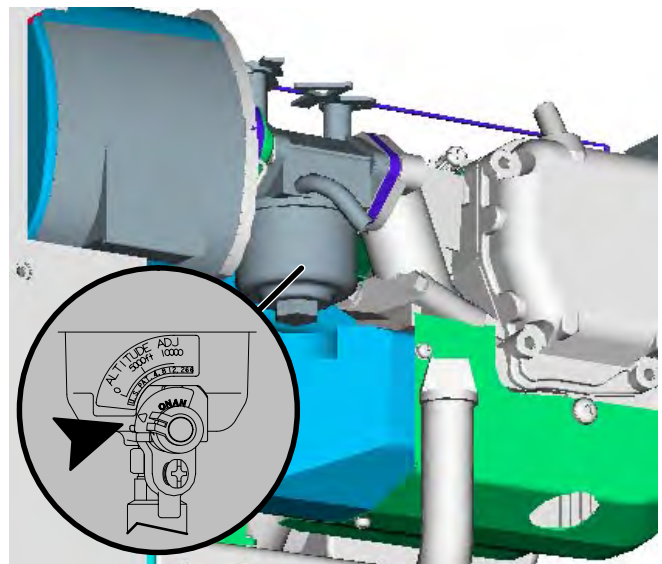

FIGURE 8. ALTITUDE ADJUST KNOB

OPERATING IN DUSTY ENVIRONMENTS

Pay particular attention to the following items when operating the genset in dusty environments:

1. Do not let dirt and debris accumulate inside the genset compartment. Keep the genset clean.
2. Perform air cleaner maintenance more often (Page 14).
3. Change engine oil every 50 hours.
4. Keep containers of engine oil that have been opened tightly closed to keep out dust.

BREAKING IN A NEW ENGINE

Proper engine break-in on a new genset or on one with a rebuilt engine is essential for top engine performance and acceptable oil consumption. Run the genset at approximately 1/2 rated power for the first 2 hours and then at 3/4 rated power for 2 more hours. See LOADING THE GENSET (Page 9).

Proper engine oil and oil level are especially critical during break-in because of the higher engine temperatures that can be expected. Change the oil if not appropriate for the ambient temperatures during break-in. See ENGINE OIL RECOMMENDATIONS (Page 6). Check oil level twice a day or every 4 hours during the first 20 hours of operation and change the oil after the first 20 hours of operation.

EXERCISING THE GENSET

Exercise the genset at least 2 hours each month if use is infrequent. Run the genset at approximately 1/2 rated power. See LOADING THE GENSET (Page 9). A single two hour exercise period is better than several shorter periods.

Exercising a genset drives off moisture, re-lubricates the engine, replaces stale fuel in fuel lines and carburetor and removes oxides from electrical contacts and generator slip rings. The result is better starting, more reliable operation and longer engine life.

STORING THE GENSET

Proper storage is essential for preserving top genset performance and reliability when the genset cannot be exercised regularly and will be idle for more than 120 days.

Storing the Genset

1. Fill the fuel tank with fresh fuel and add a fuel preservative (OnaFresh™), following the instructions on the container label. Unless a preservative (stabilizer) is added, the gasoline in the fuel system will deteriorate causing fuel system corrosion, gum formation and varnish-like deposits which can lead to hard starting and rough operation.

Then run the genset for about 10 minutes at approximately 1/2 rated power to fill the fuel lines with the fresh fuel and preservative.

⚠WARNING *Gasoline preservatives (stabilizers) are toxic. Follow the instructions on the container label. Avoid skin contact. Wash your hands with soap and water after dispensing the fluid.*

2. Change the engine oil and attach a tag indicating its oil viscosity (Page 6).
3. Remove the air filter and restart the genset. While the genset is running, spray an engine fogger (OnaGard™) into the carburetor, following the instructions on the container label, and then stop the genset. The fogger leaves a protective coat of oil on the internal surfaces of the engine.
4. Disconnect the battery cables, negative (-) cable first, from the starting battery and store the battery according to the battery manufacturer's recommendations (Page 18).
5. Plug the exhaust tail pipe to keep out dirt, moisture, rodents and such.
6. Close the fuel supply valve (if so equipped).
7. Turn OFF the AC circuit breaker (Page 10).

⚠WARNING Do not open the carburetor drain when the engine is hot. Close the drain immediately after draining. Failure to heed this warning can lead to fire resulting in severe personal injury or death.

8. Draining the carburetor float bowl prevents deposits of gum from clogging the tiny passages in the carburetor as the gasoline in the bowl evaporates during storage. If the carburetor has a drain (Figure 9), drain it as follows:
 - A. Let the engine cool down thoroughly.
 - B. Place paper towels under the drain to absorb all of the drainage (less than 1/2 cup).
 - C. Open the drain valve by turning counter-clockwise with a screwdriver.
 - D. Immediately close the drain valve after draining by turning clockwise with a screwdriver *until just snug*.

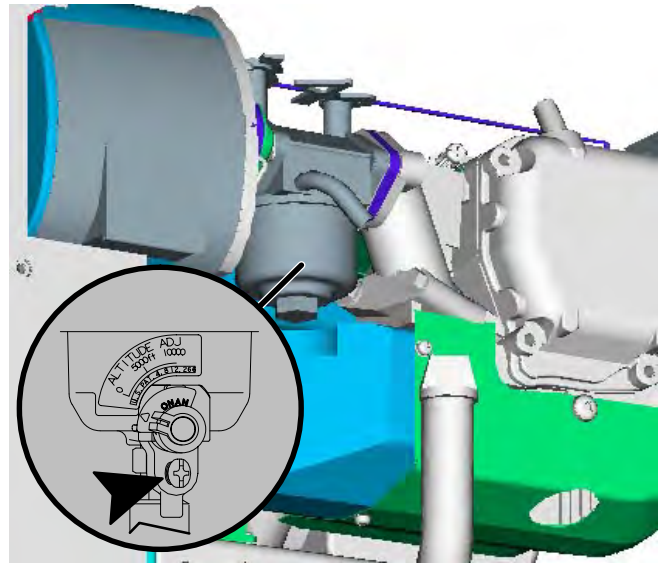

FIGURE 9. CARBURETOR DRAIN VALVE

Returning The Genset To Service

1. Check the oil tag on the genset and change the oil if the viscosity indicated is not appropriate for the temperatures expected (Page 6).
2. Reconnect the starting battery, negative (-) cable last (Page 18).
3. Remove the plug from the exhaust tailpipe.
4. Change the air filter element if it is dirty.
5. Open the fuel supply valve (if so equipped).
6. Inspect the genset (Page 15).
7. Start the genset. There may be smoke and rough operation for a few minutes until the oil from the fogger burns off. If the engine does not start, clean or replace the spark plug, which may have been fouled by the fogger.
8. Turn ON the AC circuit breaker (Page 10) when the genset is ready to power appliances.

Periodic Maintenance

Periodic maintenance is essential for top performance and long genset life. Use Table 4 as a guide for normal periodic maintenance. In hot and dusty environments some maintenance procedures should be performed more frequently, as indicated by the footnotes in the table. Keeping a log of maintenance performed and hours run will help you keep

genset maintenance regular and provide a basis for supporting warranty claims (Page 25).

Maintenance, replacement or repair of emission control devices and systems may be performed by any engine repair establishment or individual. However, warranty work must be completed by an authorized Onan dealer.

TABLE 4. PERIODIC MAINTENANCE SCHEDULE

MAINTENANCE PROCEDURE	MAINTENANCE FREQUENCY							Page
	Every Day or Every 8 Hours	After First 20 Hours	Every Month	Every 50 Hours	Every 150 Hours	Every 200 Hours	Every 450 Hours	
General Inspection	X							15
Check Engine Oil Level	X							16
Clean and Check Battery			X ³					18
Clean Spark Arrestor				X				19
Change Engine Oil		X ¹			X ^{2, 3, 4}			17
Replace Air Filter Element					X ²			18
Clean Engine Cooling Fins						X ²		-
Replace Spark Plug							X ⁵	19
Replace Fuel Filter							X ⁵	20
Adjust Valve Lash							X ⁶	-
Clean/Replace Cylinder Head							X ⁶	-

- 1 - As a part of engine break-in, change the engine oil after the first 20 hours of operation.
- 2 - Perform more often when operating in dusty environments.
- 3 - Perform more often when operating in hot weather.
- 4 - Perform at least once a year.
- 5 - Perform sooner if engine performance deteriorates.
- 6 - Must be performed by a qualified mechanic (authorized Onan dealer).

CONDUCTING GENERAL INSPECTIONS

Inspect the genset before the first start of the day and after every eight hours of operation.

Oil Level

Check engine oil level (Page 16).

Exhaust System

Look and listen for exhaust system leaks while the genset is running. Shut down the genset if a leak is found and have it repaired before operating the genset again.

Look for openings or holes between the genset compartment and vehicle cab or living space if the genset engine sounds louder than usual. Have all such openings or holes closed off or sealed to prevent exhaust gases from entering the vehicle.

Replace dented, bent or severely rusted sections of the tailpipe and make sure the tailpipe extends at least 1 inch (25.4 mm) beyond the perimeter of the vehicle.

Park the vehicle so that the genset exhaust gases can disperse away from the vehicle. Barriers such as walls, snow banks, high grass, brush and other vehicles can cause exhaust gases to accumulate in and around the vehicle.

Do not operate power ventilators or exhaust fans while the vehicle is standing with the genset running. The ventilator or fan can draw exhaust gases into the vehicle.

⚠️WARNING ***EXHAUST GAS IS DEADLY! Do not operate the genset if there is an exhaust leak or any danger of exhaust gases entering or being drawn into the vehicle.***

⚠️WARNING ***Do not park the vehicle in high grass or brush. Contact with the exhaust system can cause a fire.***

Fuel System

Check for leaks at the hose, tube and pipe fittings in the fuel supply system while the genset is running

and while it is stopped. Check flexible fuel hose sections for cuts, cracks, and abrasions. Make sure the fuel line is not rubbing against other parts. Replace worn or damaged fuel line parts before leaks occur.

⚠️WARNING ***Gasoline is highly flammable and explosive and can cause severe personal injury or death. Shut down the genset and repair leaks immediately.***

Battery Connections

Check the battery terminals for clean, tight connections. Loose or corroded connections have high electrical resistance which makes starting harder. See MAINTAINING THE BATTERY AND BATTERY CONNECTIONS (Page 18).

⚠️WARNING ***Arcing at battery terminals or light switch or other equipment or flames and sparks can ignite battery gas causing severe personal injury—Ventilate battery area before working on or near battery—Wear safety glasses—Do not smoke—Switch trouble light ON / OFF away from battery—Do not disconnect battery cables while genset is running or vehicle battery charging system is on—Always disconnect negative (-) cable first and reconnect it last.***

Mechanical

Look for mechanical damage. Start the genset and look, listen and feel for any unusual noises and vibrations.

Check the genset mounting bolts to make sure they are secure.

Check to see that the genset air inlet and outlet openings are not clogged with debris or blocked.

Clean accumulated dust and dirt from the genset. Do not clean the genset while it is running or still hot. Protect the generator, air cleaner, control panel, and electrical connections from water, soap and cleaning solvents.

⚠️WARNING ***Always wear safety glasses when using compressed air, a pressure washer or a steam cleaner to avoid severe eye injury.***

CHECKING ENGINE OIL LEVEL

Park the vehicle on level ground and stop the genset before checking engine oil level.

⚠ WARNING *Crankcase pressure can blow hot engine oil out the fill opening causing severe burns. Always stop the genset before removing the oil fill cap.*

1. Unscrew the oil fill cap and wipe oil off the dipstick (Figure 10). Reinsert the dipstick, **but do not screw the cap down**. Remove the dipstick again and check the oil level on the dip stick.
2. Add or drain oil as necessary. See ENGINE OIL RECOMMENDATIONS (Page 6). Keep the oil level between the FULL and ADD marks.

⚠ CAUTION *Too much oil can cause high oil consumption. Too little oil can cause severe engine damage. Keep the oil level between the FULL and ADD marks.*

3. Screw the oil fill cap back on securely.

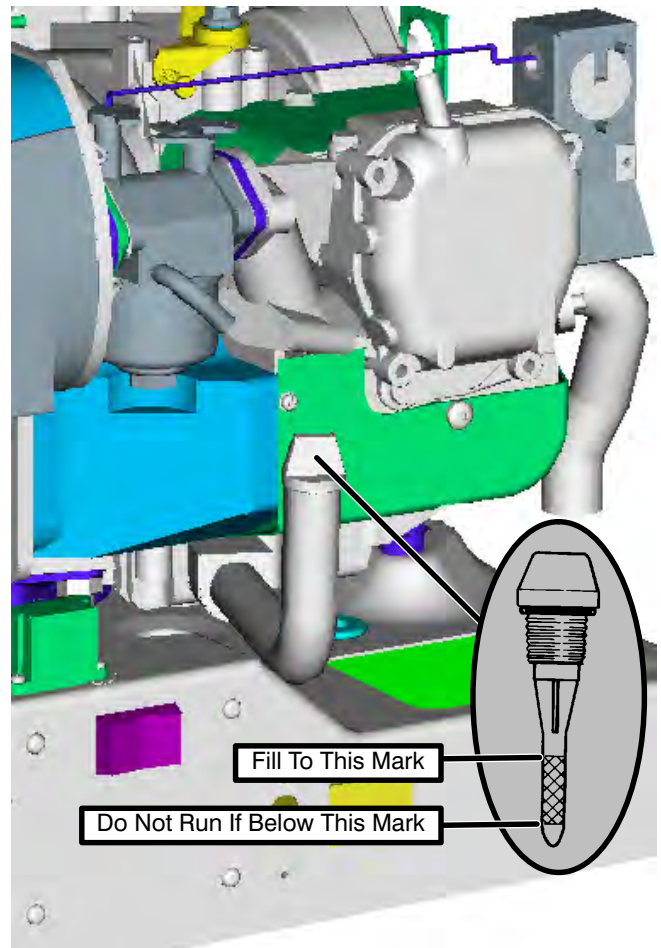

FIGURE 10. CHECKING ENGINE OIL LEVEL

CHANGING ENGINE OIL

⚠WARNING *State and federal agencies have determined that contact with used engine oil can cause cancer or reproductive toxicity. Try to avoid skin contact and breathing of vapors. Use rubber gloves and wash exposed skin.*

Refer to Table 4 for scheduled engine oil change. Change oil more often in hot and dusty environments.

⚠WARNING *Crankcase pressure can blow hot engine oil out the fill opening causing severe burns. Always stop the genset before removing the oil fill cap.*

1. Run the engine until warm, stop it and remove the oil fill cap (Figure 10).
2. Place a pan under the oil drain plug and remove the plug (Figure 11) with a 14 mm socket. Let all oil drain from the engine and then **secure the drain plug**.
3. Refill with 1 quart (0.95 l) of oil. See ENGINE OIL RECOMMENDATIONS (Page 6). Check the oil level and add or drain oil as necessary.
4. Screw the oil fill cap on securely.
5. Dispose of the used oil in accordance with local environmental regulations.

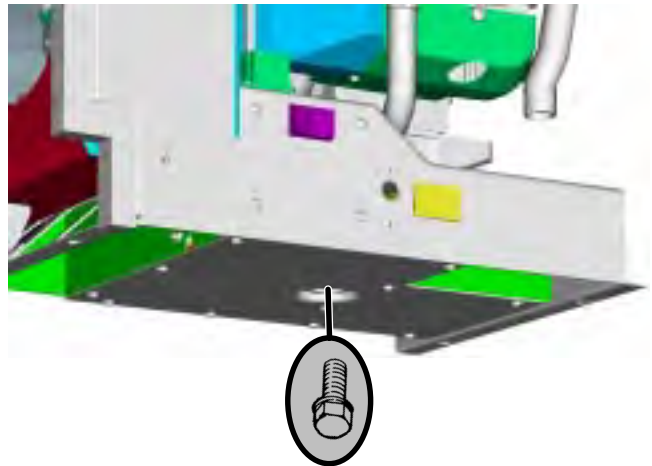

FIGURE 11. OIL DRAIN PLUG

REPLACING THE AIR FILTER ELEMENT

Refer to Table 4 for scheduled air filter replacement. Under dusty operating conditions inspect and change the air filter element more often. To change the air filter element (Figure 12), lift the filter cover out of the scroll housing and pull the filter retainer straight out. Install the new filter with the open end of the filter facing the carburetor, as shown.

MAINTAINING THE BATTERY AND BATTERY CONNECTIONS

⚠WARNING *Arcing at battery terminals or light switch or other equipment or flames and sparks can ignite battery gas causing severe personal injury—Ventilate battery area before working on or near battery—Wear safety glasses—Do not smoke—Switch trouble light ON / OFF away from battery—Do not disconnect battery cables while genset is running or vehicle battery charging system is on—Always disconnect negative (-) cable first and reconnect it last.*

Refer to Table 4 for scheduled battery maintenance, referring to the battery manufacturer's instructions. Have the battery charging system serviced if DC system voltage is consistently low or high. Always:

1. Keep the battery case and terminals clean and dry and the terminals tight.
2. Remove battery cables with a battery terminal puller.
3. Make sure which terminal is positive (+) and which is negative (-) before making battery connections, always removing the negative (-) cable first and reconnecting it last to reduce arcing.

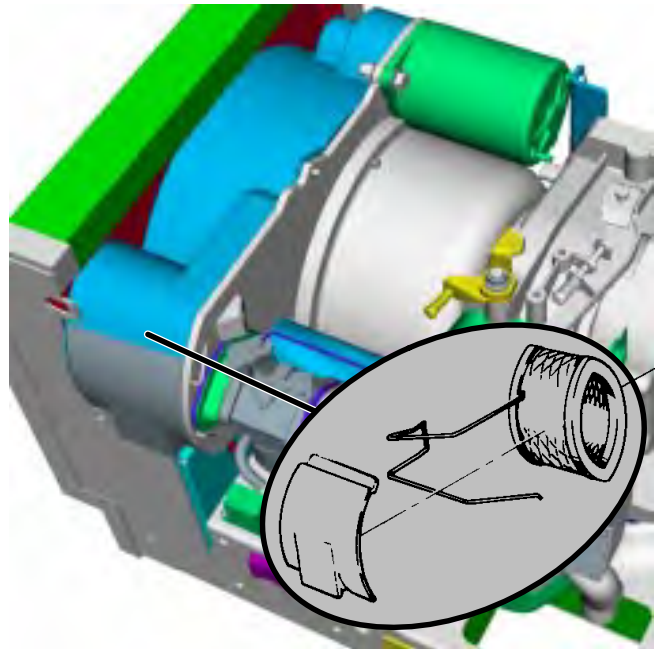

FIGURE 12. AIR FILTER ELEMENT

REPLACING THE SPARK PLUG

Refer to Table 4 for scheduled spark plug replacement. (The genset has one spark plug, Figure 13). The spark plug must be in good condition for proper engine starting and performance. A spark plug that fouls frequently or has heavy soot deposits indicates that the engine needs service. See *Troubleshooting* (Page 21).

Always thread the spark plug in by hand until it seats, to prevent crossthreading, and torque to 13 lbs-ft (17 N-m). If you don't have a torque wrench, turn the spark plug an additional 1/4 turn, if being reused, or 3/8 to 1/2 turns if new.

CLEANING THE SPARK ARRESTOR

Refer to Table 4 for scheduled cleaning of the spark arrester muffler (which meets U.S. Forest Service requirements). Cleaning is required for maximum genset performance.

⚠WARNING *A hot muffler can cause severe burns. Let the muffler cool down before removing the spark arrester screen.*

The spark arrester screen is mounted inside the muffler outlet (Figure 14). Clean as follows:

4. Loosen the U-bolt clamp that secures the tailpipe to the muffler and move the tailpipe aside.
5. Remove the screw that secures the spark arrester tube/screen inside the muffler outlet.
6. Remove the spark arrester tube and inspect the screen inside for damage and clogging. Replace if damaged.
7. Lightly tap the spark arrester and remove any remaining deposits with a wire brush. Use a commercial solvent to loosen hard deposits. (Carefully follow the solvent manufacturer's instructions and safety precautions.)
8. Reinstall the spark arrester and tail pipe.

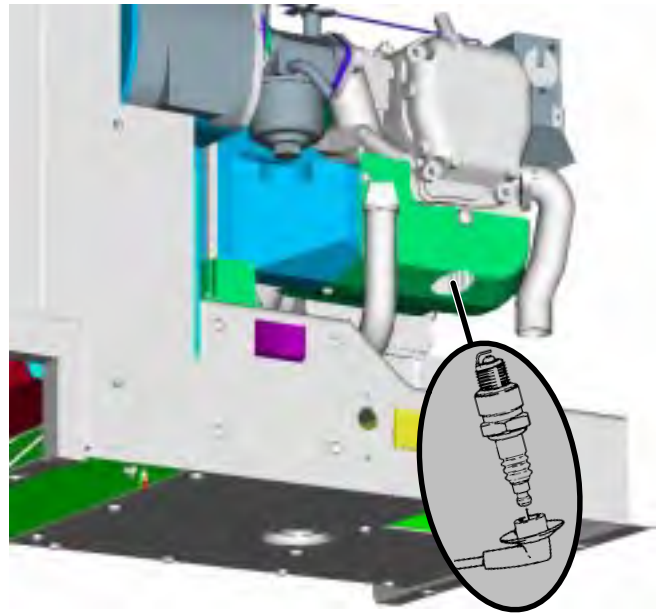

FIGURE 13. SPARK PLUG

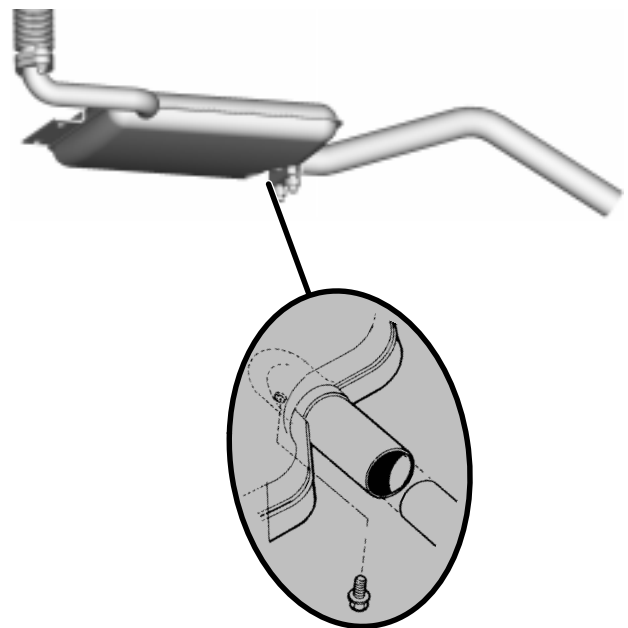

FIGURE 14. SPARK ARRESTOR

REPLACING THE FUEL FILTER

Refer to Table 4 for scheduled replacement of the fuel filter (Figure 15).

Take care to spill as little fuel as possible when disconnecting the filter from the fuel line. Close any shut off valve in the fuel line and let the engine cool down before disconnecting the fuel line so that it cannot ignite any fuel that is spilled. The filter is removable by loosening the hose clamps shown.

⚠WARNING *Gasoline is highly flammable and can cause severe personal injury or death—Let the engine cool and close any fuel line shutoff valve before disconnecting the fuel line from the filter—Do not smoke or turn electrical switches ON or OFF where fuel fumes, tanks or equipment are present or in areas sharing ventilation. Keep flame, sparks, pilot lights, arc-producing equipment and switches and all other sources of ignition well away. Keep a type ABC fire extinguisher in the vehicle.*

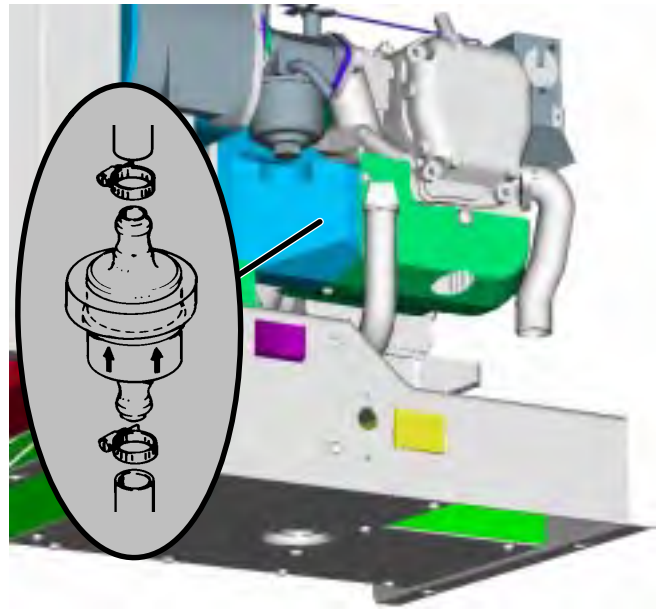

FIGURE 15. FUEL FILTER

Troubleshooting

Table 5 provides basic troubleshooting guidance. If you fail to resolve the problem after taking the corrective actions suggested, contact an authorized Onan dealer. See *How to Obtain Service* (Page 24).

⚠WARNING *Hot engine parts can cause severe burns. Always allow the engine time to cool before performing any maintenance or service.*

⚠WARNING *Many troubleshooting procedures present hazards that can result in severe personal injury or death. Only trained and experienced service personnel with knowledge of fuels, electricity, and machinery hazards should perform service procedures. Review Safety Precautions.*

TABLE 5. TROUBLESHOOTING

Problem	Corrective Action
1. Engine fails to crank	<ul style="list-style-type: none"> a. Try starting at the genset rather than at the remote control. b. Clean and tighten the positive (+) and negative (-) battery cable connections at the battery and at the genset. c. Recharge the battery. Refer to the battery manufacturer's recommendations.
2. Engine cranks slowly	<ul style="list-style-type: none"> a. Disconnect the air conditioner and other large loads. b. Clean and tighten the positive (+) and negative (-) battery cable connections at the battery and at the genset. c. Recharge the battery. Refer to the battery manufacturer's recommendations. d. Change the engine oil to oil having the proper viscosity for the ambient temperature (Pages 6 and 17).
3. Engine cranks but fails to start	<ul style="list-style-type: none"> a. Check the fuel tank and fill if necessary. b. Open any closed fuel shut off valve. c. Check engine oil level and add or drain oil, as necessary (Page 16). d. Service the air cleaner (Page 18). e. Replace the fuel filter (Page 20). f. Secure the spark plug lead on the spark plug. g. Replace the spark plug (Page 19).
4. Engine runs but stops or surges	<ul style="list-style-type: none"> a. Check the fuel tank and fill if necessary. b. Check engine oil level and add or drain oil, as necessary (Page 16). c. Reset the carburetor for altitude, as necessary (Page 11). d. Secure the spark plug lead on the spark plug. e. Replace the spark plug (Page 19).
5. Genset stalls or circuit breakers trip	<ul style="list-style-type: none"> a. Connect fewer appliances (Page 9).
6. No electrical power when genset running	<ul style="list-style-type: none"> a. Reset tripped circuit breakers (Page 10). b. Unless there is an automatic power transfer switch, plug the vehicle power cord into the genset power output receptacle (if so equipped) or turn the vehicle power selector switch to its genset position (if so equipped).
7. DC voltmeter (Page 7) indicates low voltage	<ul style="list-style-type: none"> a. Clean and tighten the positive (+) and negative (-) battery cable connections at the battery and the genset. b. Recharge the battery. Refer to the battery manufacturer's recommendations.
8. Black smoke out tailpipe	Service the air cleaner (Page 18).

Specifications

GENERATOR: 2-Pole Revolving Field, Self-Excited, 1-Phase, Electronically Regulated		
Power	2800 watts	2800 watts
Frequency	60 Hertz*	60 Hertz
Voltage	120 volts	100 volts
Current	23.3 amperes	28 amperes
Speed	3600 rpm	3600 rpm
FUEL CONSUMPTION:		
	Gasoline	Gasoline
No load	0.16 gph (0.6 l/h)	0.16 gph (0.6 l/h)
Half load	0.28 gph (1.1 l/h)	0.28 gph (1.1 l/h)
Full load	0.46 gph (1.7 l/h)	0.46 gph (1.7 l/h)
ENGINE: 1-Cylinder, 4-Stroke Cycle, Spark-Ignited, OHV, Air Cooled, Mechanically Governed		
Bore	2.64 inch (67 mm)	2.64 inch (67 mm)
Stroke	2.2 inch (56 mm)	2.2 inch (56 mm)
Displacement	12 inch ³ (197 cc)	12 inch ³ (197 cc)
Compression Ratio	8.5 : 1	8.5 : 1
Oil Capacity	1 quart (0.95 l)	1 quart (0.95 l)
Intake Valve Lash (Cold)	0.002 inch (0.05 mm)	0.002 inch (0.05 mm)
Exhaust Valve Lash (Cold)	0.002 inch (0.05 mm)	0.002 inch (0.05 mm)
Spark Plug Gap	0.025 inch (0.64 mm)	0.025 inch (0.64 mm)
Spark Plug Tightening Torque	13 lbs-ft (17 N-m)	13 lbs-ft (17 N-m)
Ignition Timing (magneto type ignition)	25° BTDC, non-adjustable	25° BTDC, non-adjustable
DC SYSTEM:		
Nominal Battery Voltage	12 volts	12 volts
Min. Battery Rating: Cold Cranking Amps (CCA) @ 0° F (-18° C)	360/450 above/below 32° F (0° C)	360/450 above/below 32° F (0° C)
Control Fuse	5 amperes	5 amperes
INSTALLATION:		
Weight of Genset (with engine oil)	100 lbs (45 kg)	
Minimum Compartment Size (H x D x W)**	15.5 inch x 17.5 inch x 20.2 inch (394 mm x 445 mm x 512 mm)	
Minimum Free Air Inlet Area	40 inch ² (258 cm ²)	
Muffler Outlet Collar O. D.	1.13 inch	
Fuel Connection	1/4 inch barb fitting for gasoline hose	
* Listed by CSA and the U. S. Testing Company.		
** See the Installation Manual for additional considerations when sizing the genset compartment.		

Information for California Genset Users

This genset meets the requirements of California's Exhaust Emissions Standards as stated on the nameplate. Figure 1 (Page 4) illustrates where this information appears on the nameplate.

As a California user of these gensets, please be aware that unauthorized modifications or replacement of fuel, exhaust, air intake, or speed control system components that affect engine emissions are prohibited. Unauthorized modification, removal or replacement of the genset label is prohibited.

You should carefully review Operator (Owner), Installation and other manuals and information you receive with your genset. If you are unsure that the installation, use, maintenance or service of your genset is authorized, you should seek assistance from an approved Onan dealer.

California genset users may use Table 6 as an aid in locating information related to the California Air Resources Board requirements for emissions control.

TABLE 6. EMISSIONS CONTROL INFORMATION

Genset Warranty Information	The California emissions control warranty statement is located in the same packet of information as this manual when the genset is shipped from the factory.
Engine Valve Lash	See <i>Specifications</i> (Page 22).
Engine Ignition Timing	See <i>Specifications</i> (Page 22).
Engine Fuel Requirements	The engine is certified to operate on unleaded gasoline. See FUEL RECOMMENDATIONS (Page 6).
Engine Lubricating Oil Requirements	See ENGINE OIL RECOMMENDATIONS (Page 6).
Engine Fuel Mixture Settings	These genset engines have precision-manufactured carburetors which are not adjustable except for altitude (Figure 8, Page 11).
Engine Adjustments	None.
Engine Emission Control System	The engine emission control system consists of inherent engine design.

How to Obtain Service

When you need service, parts, or product literature (such as the Service Manual) for your genset, contact the nearest authorized distributor. Onan has factory-trained representatives to handle your needs for genset parts and service.

Call 1-800-888-ONAN to contact the nearest Cummins/Onan or Onan-only distributor in the United States or Canada. (This automated service utilizes touch-tone phones only). Select OPTION 1 (press 1) to be automatically connected to the distributor nearest to you.

If you are unable to contact a distributor using the automated service, consult the Yellow Pages. Typically, our distributors are listed under:

GENERATORS - ELECTRIC,
ENGINES - GASOLINE OR DIESEL, or
RECREATIONAL VEHICLES - EQUIPMENT,
PARTS AND SERVICE.

If you are outside North America, call Onan Corporation at 1-763-574-5000 from 7:30 AM to

4:00 PM, Central Standard Time, Monday through Friday, or fax 1-763-528-7229.

Before calling for service, have the following information available:

1. *The complete genset model number and serial number. See Model Identification (Page 4).*
2. *The date of purchase*
3. *The nature of the problem. See Troubleshooting (Page 21).*

If you have difficulty in arranging service or resolving a problem, please contact the Service Manager at the nearest Cummins/Onan distributor for assistance.

⚠WARNING *Improper service or replacement of parts can result in severe personal injury, death, and/or equipment damage. Service personnel must be trained and experienced in performing electrical and/or mechanical service.*



Cummins Power Generation
1400 73rd Avenue N.E.
Minneapolis, MN 55432
763-574-5000
Fax: 763-528-7229

Cummins and Onan are registered trademarks of Cummins Inc.