

Onan

RV GenSet

Installation Manual

KVC



Printed in U.S.A.

981-0620
6-99



WARNING:



The engine exhaust from this product contains chemicals known to the State of California to cause cancer, birth defects or other reproductive harm.



WARNING



**Do not use this genset on a boat
Such use may violate U. S. Coast Guard
regulations and can result in
severe personal injury or death from
fire, electrocution, or
carbon monoxide poisoning**

Table of Contents

- SAFETY PRECAUTIONS** 2
- INTRODUCTION** 4
 - About this Manual 4
 - Installation Codes and Standards for Safety 4
 - Typical Genset 5
- LOCATION, MOUNTING AND ENCLOSURE** 6
- EXHAUST SYSTEM** 7
- FUEL CONNECTIONS** 9
- ELECTRICAL CONNECTIONS** 11
 - Generator Connections 11
 - Remote Control Connections 13
 - Battery Connections 14
- SPECIFICATIONS** 16
- INSTALLATION REVIEW AND STARTUP** 17
 - Installation Review 17
 - Startup 17
- OUTLINE DRAWING** A-1
- WIRING DIAGRAMS—120V** A-2
- WIRING DIAGRAMS—100V** A-3

Safety Precautions

Thoroughly read the **OPERATOR'S MANUAL** before operating the genset. Safe operation and top performance can be obtained only when equipment is operated and maintained properly.

The following symbols in this manual alert you to potential hazards to the operator, service person and equipment.

⚠ DANGER alerts you to an immediate hazard which will result in severe personal injury or death.

⚠ WARNING alerts you to a hazard or unsafe practice which can result in severe personal injury or death.

⚠ CAUTION alerts you to a hazard or unsafe practice which can result in personal injury or equipment damage.

Electricity, fuel, exhaust, moving parts and batteries present hazards which can result in severe personal injury or death.

GENERAL PRECAUTIONS

- Keep ABC fire extinguishers handy.
- Make sure all fasteners are secure and torqued properly.
- Keep the genset and its compartment clean. Excess oil and oily rags can catch fire. Dirt and gear stowed in the compartment can restrict cooling air.
- Before working on the genset, disconnect the negative (-) battery cable at the battery to prevent starting.
- Use caution when making adjustments while the genset is running—hot, moving or electrically live parts can cause severe personal injury or death.
- Used engine oil has been identified by some state and federal agencies as causing cancer or reproductive toxicity. Do not ingest, inhale, or contact used oil or its vapors.
- Benzene and lead in some gasolines have been identified by some state and federal

agencies as causing cancer or reproductive toxicity. Do not ingest, inhale or contact gasoline or its vapors.

- Do not work on the genset when mentally or physically fatigued or after consuming alcohol or drugs.
- Carefully follow all applicable local, state and federal codes.

GENERATOR VOLTAGE IS DEADLY!

- Generator output connections must be made by a qualified electrician in accordance with applicable codes.
- The genset must not be connected to the public utility or any other source of electrical power. Connection could lead to electrocution of utility workers and damage to equipment. An approved switching device must be used to prevent interconnections.
- Use caution when working on live electrical equipment. Remove jewelry, make sure clothing and shoes are dry and stand on a dry wooden platform.

ENGINE EXHAUST IS DEADLY!

- Learn the symptoms of carbon monoxide poisoning in this manual and never sleep in the vehicle while the genset is running unless the vehicle is equipped with a working carbon monoxide detector.
- The exhaust system must be installed in accordance with the genset Installation Manual. Engine cooling air must not be used for heating the working or living space or compartment.
- Inspect for exhaust leaks at every startup and after every eight hours of running.
- Make sure there is ample fresh air when operating the genset in a confined area.

FUEL IS FLAMMABLE AND EXPLOSIVE

- Do not smoke or turn electrical switches ON or OFF where fuel fumes are present or in areas sharing ventilation with fuel tanks or equipment. Keep flame, sparks, pilot lights, arc-producing equipment and switches and all other sources of ignition well away.

- Fuel lines must be secured, free of leaks and separated or shielded from electrical wiring.
- Leaks can lead to explosive accumulations of gas. Natural gas rises when released and can accumulate under hoods and inside housings and buildings. LPG sinks when released and can accumulate inside housings and basements and other below-grade spaces. Prevent leaks and the accumulation of gas.

BATTERY GAS IS EXPLOSIVE

- Wear safety glasses and do not smoke while servicing batteries.

- When disconnecting or reconnecting battery cables, always disconnect the negative (-) battery cable first and reconnect it last to reduce arcing.

MOVING PARTS CAN CAUSE SEVERE PERSONAL INJURY OR DEATH

- Do not wear loose clothing or jewelry near moving parts such as PTO shafts, fans, belts and pulleys.
- Keep hands away from moving parts.
- Keep guards in place over fans, belts, pulleys, etc.

Introduction

ABOUT THIS MANUAL

This manual is a guide for the installation of the KVC Series of generator sets (gensets). Proper installation is essential for safe, reliable and quiet operation. Read through this manual before starting the installation. Keep this manual and the Operator's Manual with the other vehicle manuals.

This manual addresses the following aspects of the installation:

- Location, Mounting and Enclosure
- Exhaust System
- Fuel Connections
- Electrical Connections
- Startup

⚠ WARNING *Improper installation can result in severe personal injury, death and equipment damage. The installer must be qualified to perform the installation of electrical and mechanical equipment.*

⚠ CAUTION *Unauthorized modifications or replacement of fuel, exhaust, air intake or speed control system components that affect engine emissions are prohibited by law in the State of California.*

See the Operator's Manual for operation and maintenance and the Service Manual for service.

Note: Manuals are updated from time-to-time to reflect changes in the equipment and its specifications. For this reason, only the copy of the installation manual supplied with the genset should be used as a guide for the installation.

INSTALLATION CODES AND STANDARDS FOR SAFETY

The builder of the RV or work vehicle bears sole responsibility for the selection of the appropriate genset, for its proper installation and for obtaining approvals from the authorities (if any) having jurisdiction over the installation. These sets meet the basic requirements of the Standard for Safety for Engine Generator Sets for Recreational Vehicles, ANSI/RVIA EGS-1. They are suitable for installation in accordance with:

- NFPA No. 70, Article 551—Recreational Vehicles and RV Parks
- ANSI A119.2 (NFPA No. 501C)—Recreational Vehicles
- CSA Electrical Bulletin 946—Requirements for Internal Combustion Engine-Driven Electric Generators for Use in Recreational Vehicles

Federal, State and local codes, such as the California Administrative Code—Title 25 (RV installation), might also be applicable. Installation codes and recommendations can change from time-to-time and are different in different countries, states and municipalities. Obtain the standards in Table 1 for reference.

TABLE 1. REFERENCE CODES AND STANDARDS

NFPA No. 70 NFPA NO. 501C	National Fire Protection Association 470 Atlantic Avenue Boston, MA 02210
ANSI A119.2 ANSI/RVIA-EGS-1 FMVSS 301	Recreational Vehicle Industry Association 14650 Lee Road Chantilly, VA 22021
California Administrative Code—Title 25, Chapter 3	State of California Documents Section P.O. Box 1015 North Highlands, CA 95660
CAN/CSA-Z240 Recreational Vehicles Bulletin 946	Canadian Standards Association Housing and Construction Materials Section 178 Rexdale Blvd. Rexdale, Ontario, Canada M9W 1R3

TYPICAL GENSET

Figure 1 illustrates a typical genset installation. For clarity, the genset compartment door and front panels (provided by the vehicle manufacturer) are not shown. See OUTLINE DRAWING (Page NO TAG) for installation details: mounting bolt hole locations,

connection points (fuel, battery, remote control, AC output and exhaust), sizes and types of fittings, inlet and outlet air openings, weight and overall dimensions, etc. See your Onan dealer for large-scale copies of the drawings.

CAUTION Do not tip the genset forward or oil will spill into the breather.

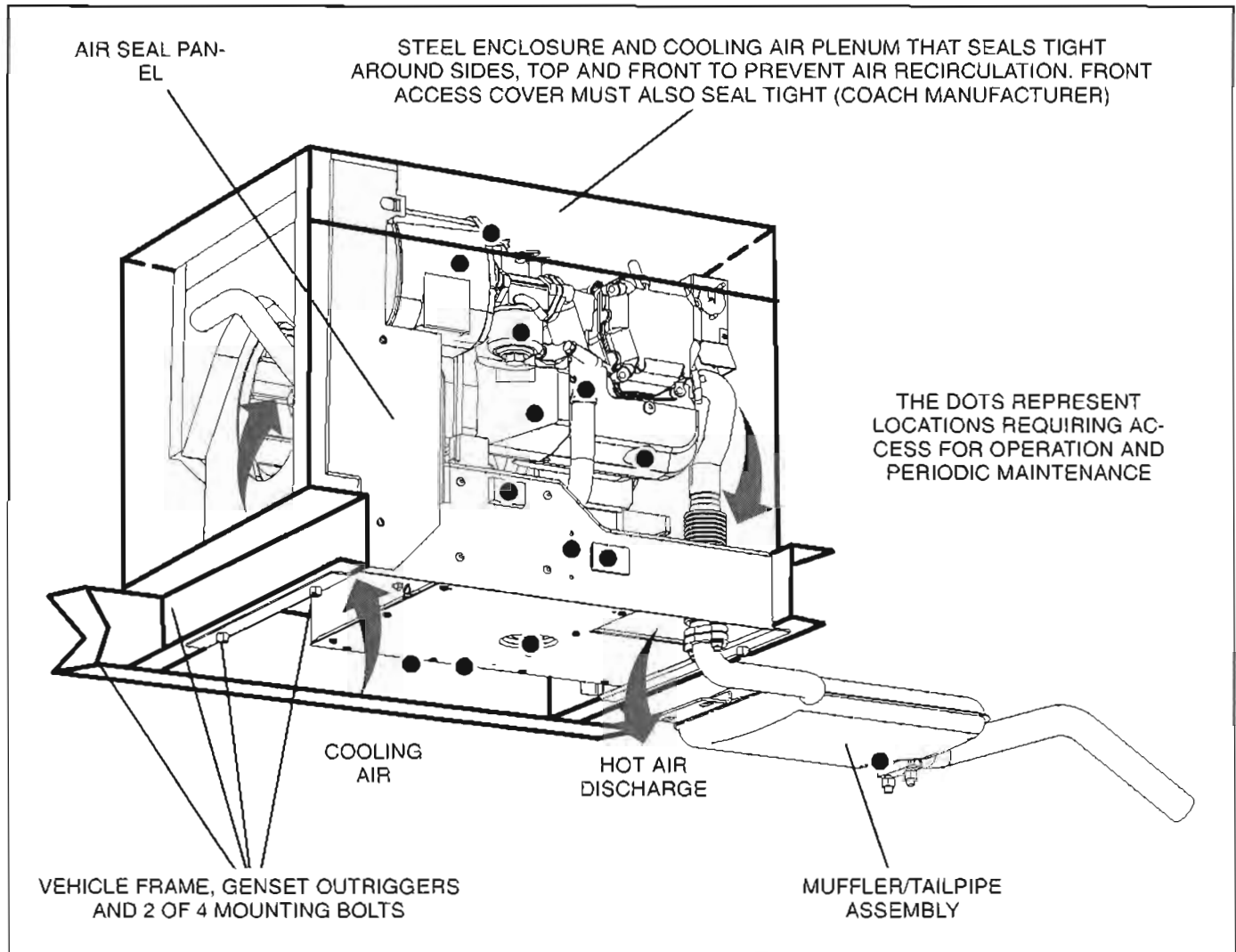

FIGURE 1. TYPICAL GENSET INSTALLATION

Location, Mounting and Enclosure

These gensets are designed for installation inside a steel compartment that forms the cooling air plenum of the genset (Figure 1). The cooling air inlet and hot air discharge openings are both in the bottom of the genset. The genset has mounting flanges and is meant to be lifted up to the bottom of the vehicle frame outriggers and bolted.

1. The location must be such that the tailpipe clears the back of the coach body by at least 1 inch (25.4 mm) when installed (Figure 3).
2. Support the genset on a structure able to resist the dynamic weight of the genset: cyclic forces of at least $300 \pm$ lbs (± 3 g-force) vertical and $100 \pm$ lbs (± 1 g-force) horizontal.

⚠WARNING *The genset can fall from the vehicle if the supporting structure is too weak and cause severe personal injury or death. Design the structure carefully, follow applicable mounting kit instructions and torque mounting bolts properly.*

3. The genset compartment must be sized according to the outline drawing (Page NO TAG). Construction must be such that the compartment forms a good seal against the foam seal strips shown in Figure 2, to prevent warm air off the engine from recirculating back into the blower inlet. The air seal panel (Figure 1) pre-

vents air recirculation in front. It must be removed (two screws) before the genset can be installed or removed from the compartment.

4. The genset must be isolated from the vehicle living space to prevent the entrance of engine exhaust, gasoline vapors and noise. The genset compartment must therefore be vapor-tight and fire resistive. Do not duct genset cooling air, which can include exhaust gases, into the vehicle for heating.

⚠WARNING *EXHAUST GAS AND FIRE ARE DEADLY! — Install a vapor-tight and fire-resistive barrier of approved materials between the genset and the vehicle interior. — Do not duct genset cooling air into the vehicle for heating.*

5. The cooling air inlet and hot air discharge openings in the bottom of the genset must not be obstructed by other components.
6. Acoustic insulation and adhesive should be Classified as "Self-Extinguishing" at not less than 200°F (90°C). Acoustic insulation can absorb spilled fuel and oil and therefore should not be used underneath the genset. Insulation thickness must be such that it does not interfere with the governor mechanism (on top) or touch hot exhaust components.

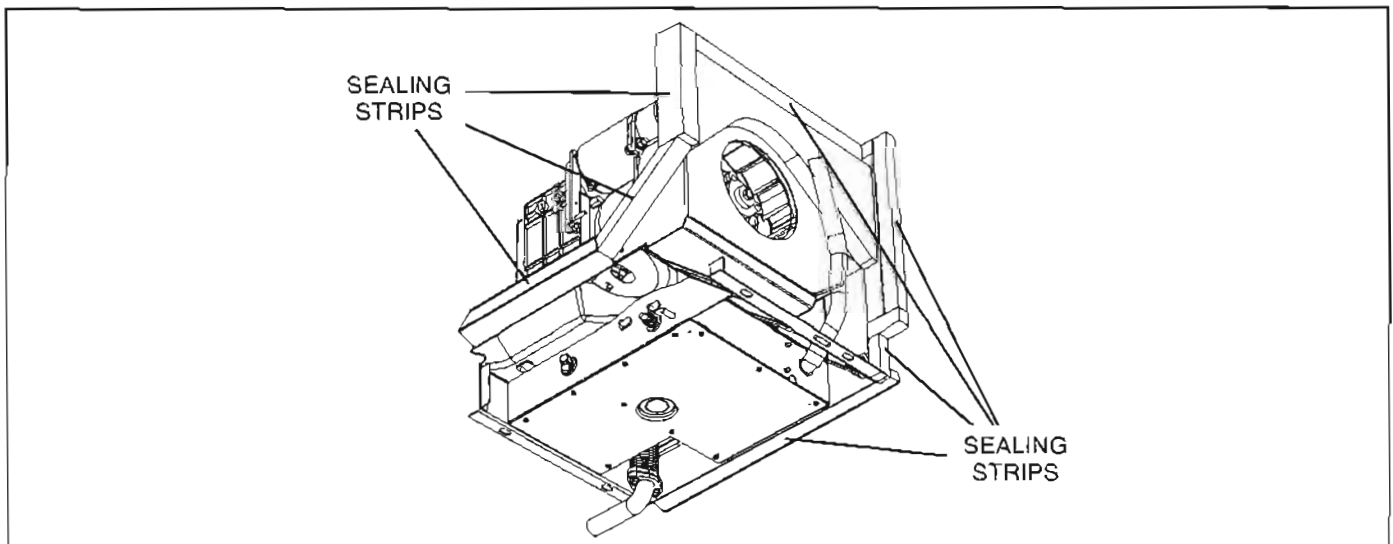

FIGURE 2. AIR SEALING STRIPS

Exhaust System

This genset must be installed with the muffler/tail pipe assembly and mounting hardware shipped with the genset (Figure 3). The muffler has a U.S. Forest Service approved spark-arrestor. Failure to provide and maintain a spark arrestor can be a violation of the law.

Liability for damage or injury, and warranty expenses due to use of unapproved mufflers becomes the responsibility of the person installing the muffler.

Contact an Onan distributor or dealer for approved exhaust system parts.

⚠WARNING *EXHAUST GAS IS DEADLY! Keep exhaust gases from entering the vehicle. Do not terminate the exhaust tailpipe underneath the vehicle or closer than 6 inches (153 mm) to openings into the vehicle or route it such that it is not protected. Use approved materials only.*

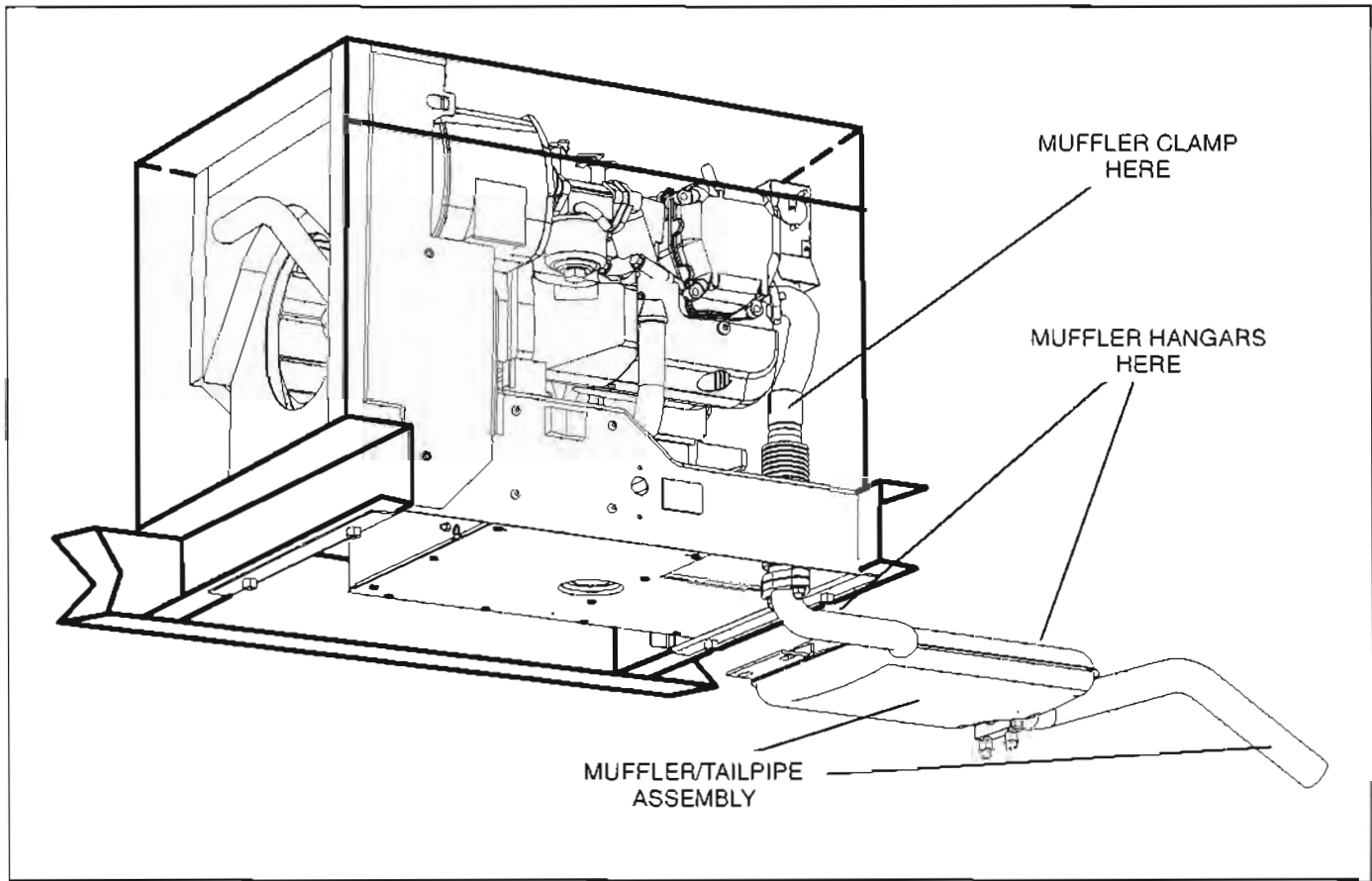

FIGURE 3. EXHAUST SYSTEM

Use the hardware in the muffler kit to install the muffler/tailpipe assembly in the orientation shown in Figure 3:

1. Be careful not to damage the flexible exhaust tube. Secure the two hangers, one on each end of the muffler so that the flexible pipe lines up exactly with the engine outlet.
2. Do not route the tail pipe near fuel lines or fuel tanks.
3. Do not mount the muffler or tailpipe closer than 3 inches (76 mm) to combustible material (wood, felt, cotton, organic fibers, etc.) unless it is insulated or shielded. The temperature rise (above ambient) on adjacent combustible material must not exceed 117° F (65° C).
4. To keep the tailpipe from being damaged, do not route it such that it protrudes into the approach or departure angles of the vehicle or below the axle clearance line (Figure 4).
5. Do not terminate the tailpipe underneath the vehicle. Extend it a minimum of 1 inch (25 mm) beyond the perimeter of the vehicle (Figure 5). Support the end of the tailpipe such that it cannot be pushed inward and up under the skirt of the vehicle.
6. Do not terminate the tailpipe such that it is closer than 6 inches (153 mm) to any opening, such as a door, window, vent or unsealed compartment, into the vehicle interior (Figure 6)

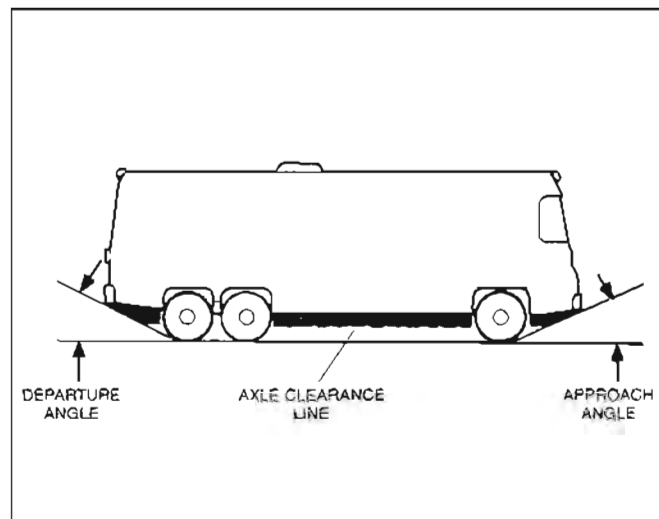

FIGURE 4. VEHICLE DEPARTURE ANGLE

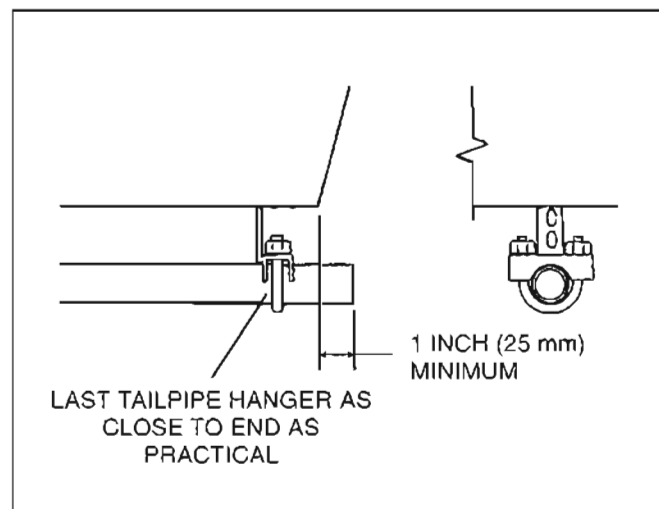

FIGURE 5. TERMINATING THE EXHAUST TAILPIPE

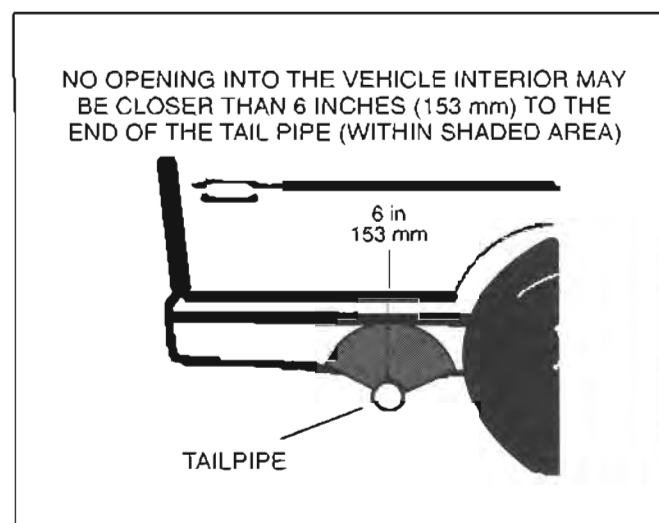

FIGURE 6. MINIMUM DISTANCES TO OPENINGS

Fuel Connections

See the Operator's Manual for recommended fuels and *Specifications* for fuel consumption rates.

⚠WARNING *Gasoline is flammable and explosive and can cause severe personal injury or death. Do not smoke or allow any flame, spark, pilot light, arc-producing equipment, switches or other ignition sources around fuel or fuel components, or in areas sharing ventilation. Keep an ABC fire extinguisher handy.*

Onan recommends a separate fuel pickup tube or a separate fuel tank for the genset. The genset must never be connected to the **fuel supply line** of the vehicle engine—either to a high-pressure system (pump in tank), which can overpressurize the genset fuel system, or to a vacuum system (pump on engine), which can cause the genset to starve for fuel. Some vehicle chassis manufacturers allow connections to the **fuel return line** on high pressure fuel systems. Contact the vehicle chassis manufacturer for approval. Fuel line pressure at the point where the genset is connected must not exceed 1-1/2 psi under any condition.

⚠WARNING *Excessive fuel pressure can flood the genset causing a fire. Genset fuel supply line pressure must not exceed 1-1/2 psi under any condition.*

For separate fuel pickup tube installations:

1. Contact the vehicle chassis manufacturer regarding installation of the second fuel pickup. Do not change or remove the fuel fill tube, fill limiter vent, vapor canister, vapor lines, filler cap or any other part of the fuel system without the approval of the vehicle chassis manufacturer. Doing so could affect vehicle engine operation or vehicle emissions regulation compliance.
2. Terminate the genset pickup above the vehicle pickup to prevent the genset from running the vehicle out of fuel.

Note: Federal standards for vehicle fuel tanks may require the installation of an automatic shutoff valve at the genset fuel tank pickup to prevent leakage in the event of a roll-over. Federal standards for vehicle impact, roll-over and emissions may also apply to a separate genset fuel tank. Check with the vehicle chassis manufacture regarding these standards.

For long runs use copper or hot dip coated seamless steel tubing (ASTM A-254) with double-flared fittings. See Figure 7 for the connection at the gen-set. Use 1/4 inch I. D. fuel hose (SAE 30-R7) and stainless steel hose clamps.

Run the fuel line at or above the top of the fuel tank to reduce the risk of siphoning fuel out of the tank if the line should break. The maximum fuel pump lift is 36 inches (914 mm).

Route gasoline fuel lines away from electrical wiring

and hot engine exhaust components. (Heat can cause fuel vapor lock.) Fuel lines should be accessible for inspection and replacement, protected from damage and secured to prevent kinking, contact with sharp edges and chafing due to vibration.

⚠WARNING *Sparks can ignite gasoline, leading to severe personal injury or death. Do not run electrical wiring and fuel lines together. Separate them with conduit or tubing if run through the same opening. Do not tie them together.*

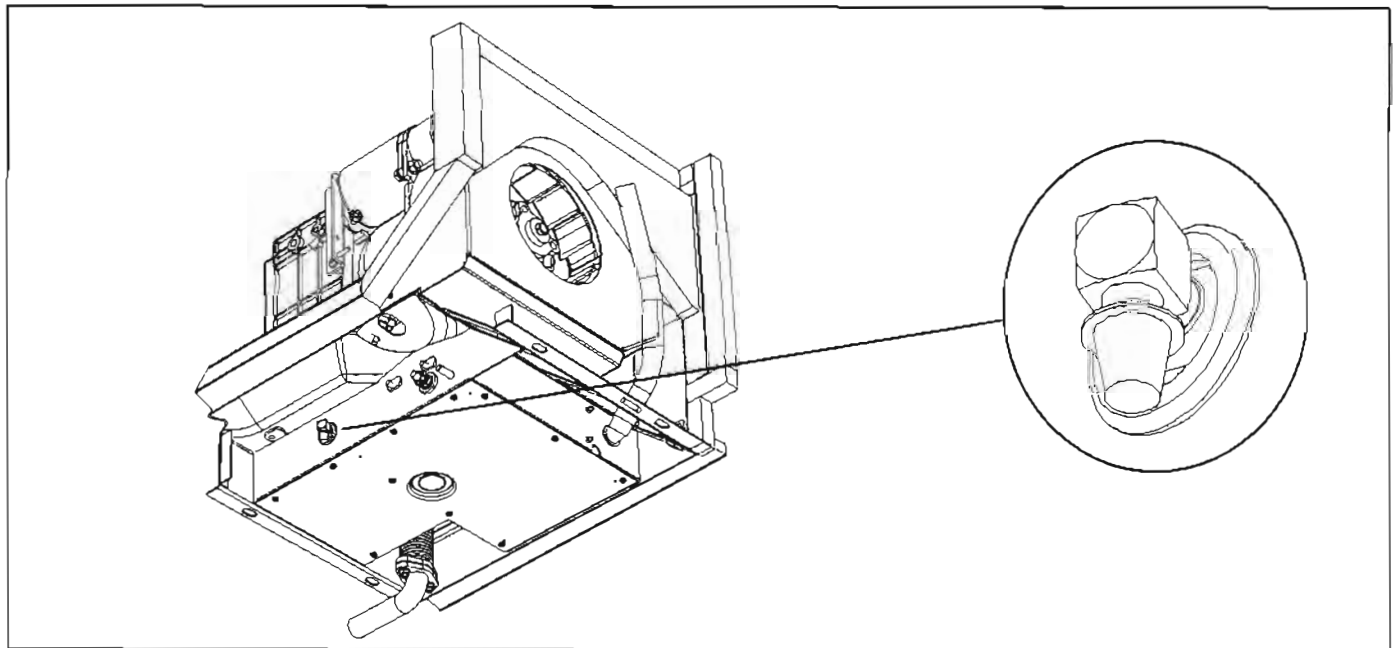

FIGURE 7. FUEL CONNECTION

Electrical Connections

Do not connect the battery cables to the battery until *Installation Review and Startup* (Page 17) to prevent accidental starting of the genset during installation.

⚠ WARNING *Accidental starting of the genset can cause severe personal injury or death. Do not connect the starting battery until *Installation Review and Startup* (Page 17).*

GENERATOR CONNECTIONS

The genset is equipped with 28 inch (715 m) long AC power output leads in 1/2 inch flexible steel conduit (Figure 8). See Figure 9 for typical connections. *If these leads must be replaced by longer leads, make sure their ampacity, as determined by the appropriate chart in the National Electrical Code (NEC), is at least 115 percent of the amps marked on the genset circuit breaker. (Unless 125° C rated wiring is available, heavier gauge wiring may be required to obtain the required ampacity.)*

Wiring Methods

Follow the National Electrical Code, especially noting the following:

1. Have a qualified electrician supervise and inspect the installation of all AC wiring.
2. Install vibration-proof switches and controls that won't open and close circuits when the vehicle is in motion.
3. Provide ground fault circuit interrupters (GFCIs) for all convenience power receptacles.
4. Route AC wiring, remote control wiring and fuel lines separately.
5. Seal all conduit openings into the vehicle interior to keep out exhaust gas. Apply silicone rubber or an equivalent type of sealant inside and outside each conduit connector. (Flexible conduit is not vapor-tight and will allow exhaust gas to enter along the wires if not sealed.)

⚠ WARNING *EXHAUST GAS IS DEADLY! Seal all wiring openings into the vehicle interior to keep out exhaust gas.*

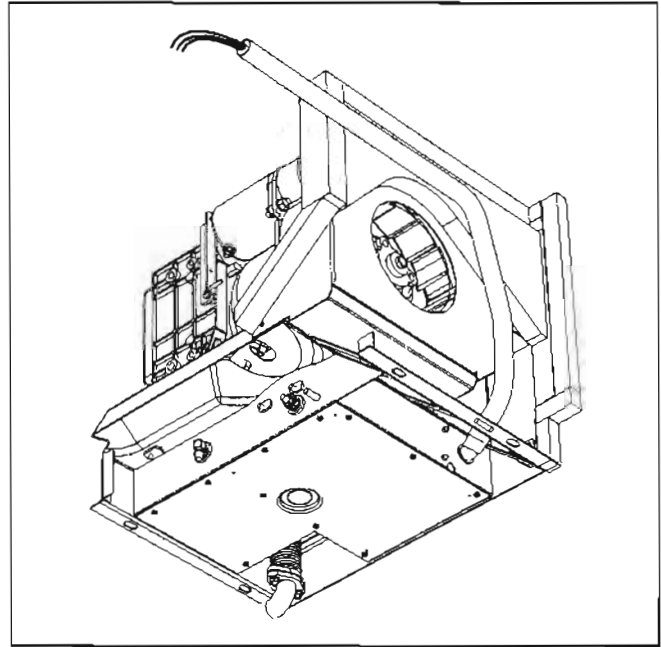

FIGURE 8. AC OUTPUT LEADS AND CONDUIT

- Bond the genset and all connected AC and DC equipment and controls to a common grounding point in accordance with applicable codes.

⚠WARNING *Faulty grounding can lead to fire and electrocution, resulting in severe personal injury or death. Grounding must be in accordance with applicable codes.*

Connecting the Vehicle to Utility Power

When the vehicle has provision for connecting utility

power it must have an approved device to keep the genset and utility from being interconnected. See Figure 9 for typical connections.

⚠WARNING *Interconnecting the genset and the public utility (or any other power source) can lead to the electrocution of personnel working on the utility lines, damage to equipment and fire. An approved switching device must be used to prevent interconnections.*

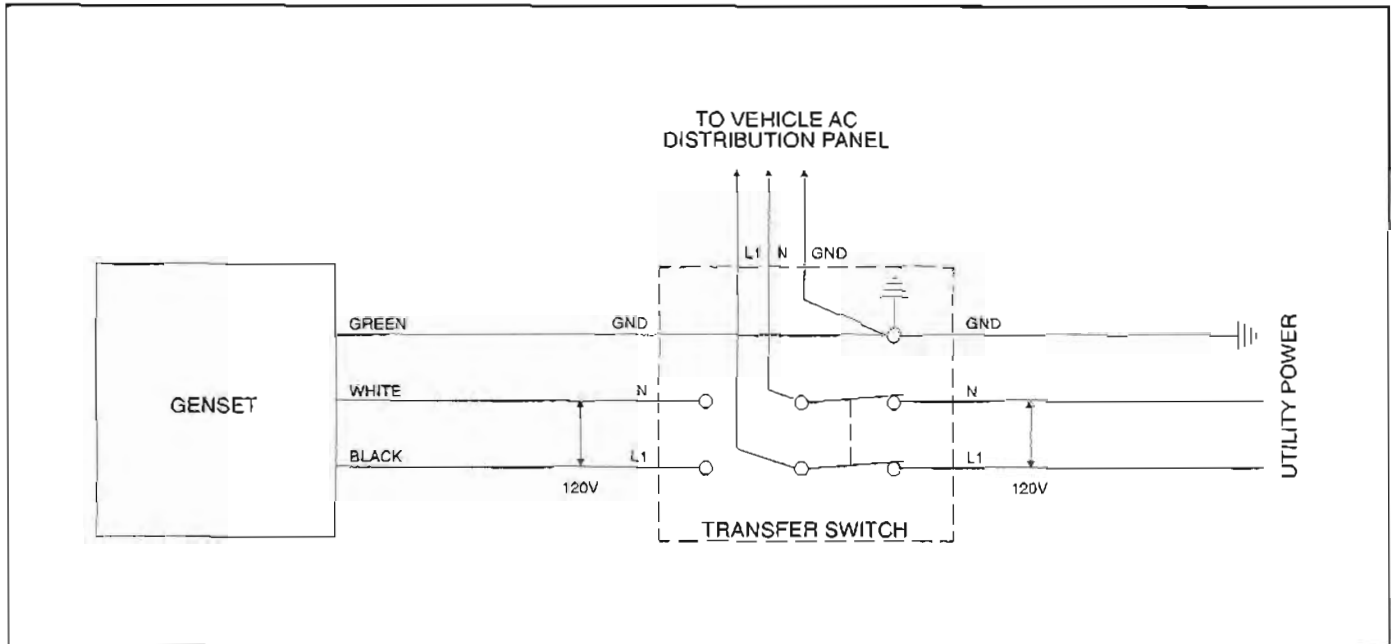

FIGURE 9. TYPICAL CONNECTIONS WITH TRANSFER SWITCH AND UTILITY

REMOTE CONTROL CONNECTIONS

Onan offers three varieties of remote control panel:

- Remote start/stop switch with indicator lamp only (Figure 10).
- Remote start/stop switch with indicator lamp and hour meter (Figure 11).
- Remote start/stop switch with indicator lamp and DC voltmeter (Figure 12).

The genset has an 8-pin connector for remote control connections (Figure 13). Remote control wiring harnesses in several lengths are available separately. To make connections to a remote control panel:

1. Snap the connector together with its mate in the wiring harness from the remote panel. If the wiring harness is made up by others, insulated 18 AWG copper conductors should be used for distances up to 30 feet (9 meters) and heavier gauge conductors for distances that are greater. Use flexible sheathing to protect remote control wiring. Figure 14 is a schematic of typical remote control connections. It identifies the function of each connector pin number. The remote panel end of each lead should be marked to identify the connector pin number.
2. Route control leads separately from AC power leads to reduce the possibility of erratic operation due to false induced signals.
3. Seal the opening where the leads enter the vehicle interior with silicone rubber or an equivalent type of sealant to keep out exhaust gas.

⚠ WARNING EXHAUST GAS IS DEADLY!
Seal all wiring openings into the vehicle interior to keep out exhaust gas.



FIGURE 10. REMOTE CONTROL

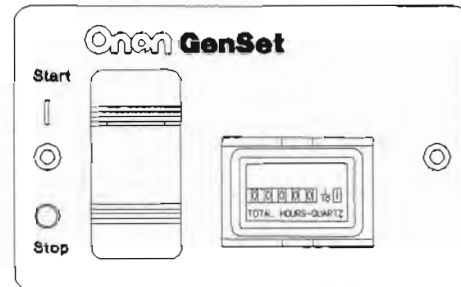

FIGURE 11. REMOTE CONTROL / HOUR METER

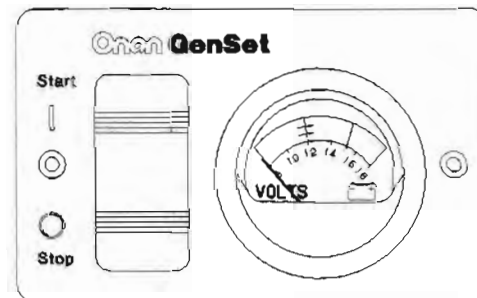

FIGURE 12. REMOTE CONTROL / DC VOLTMETER

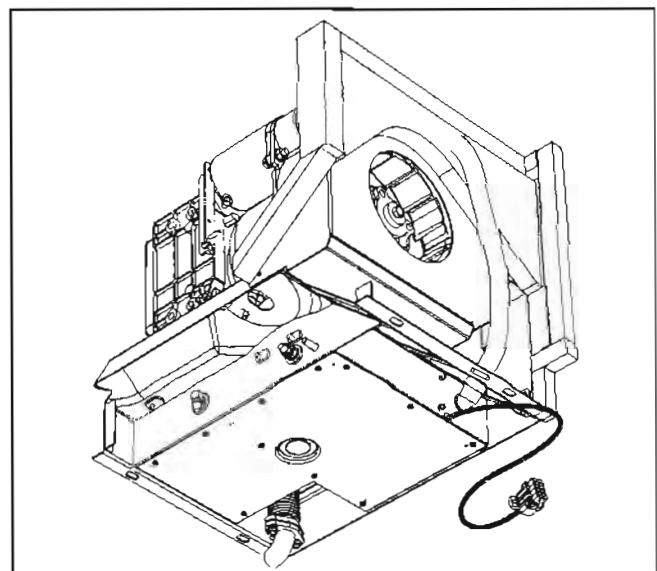

FIGURE 13. REMOTE CONTROL CONNECTOR

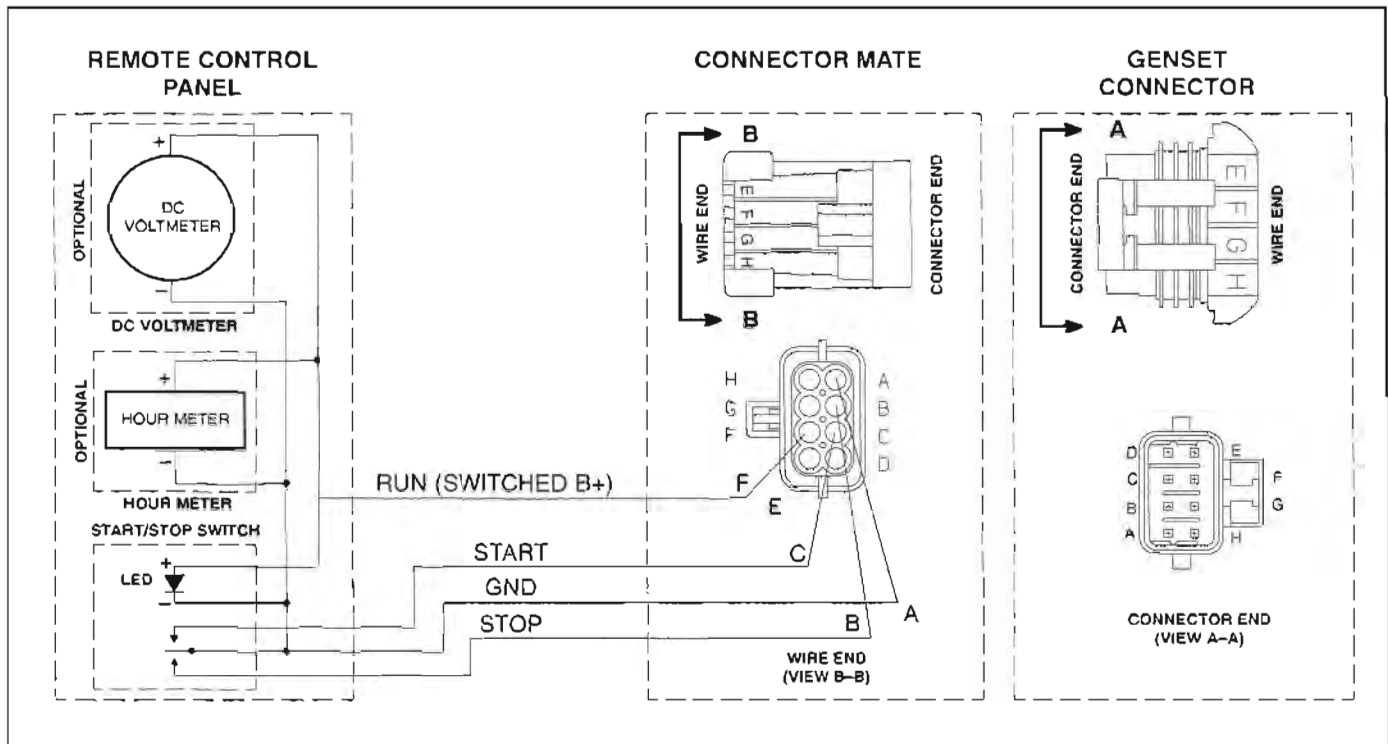

FIGURE 14. SCHEMATIC OF TYPICAL REMOTE CONTROL CONNECTIONS

BATTERY CONNECTIONS

Do not connect the battery cables to the battery until *Installation Review and Startup* (Page 17) to prevent accidental starting of the genset during installation.

⚠️WARNING *Accidental starting of the genset can cause severe personal injury or death. Do not connect the starting battery until Installation Review and Startup (Page 17).*

The genset has a 12 VDC, negative-ground engine control and cranking system. See *Specifications* for the requirements for cranking batteries.

Battery Compartment

Batteries must be mounted in a separate compartment from that of the genset and away from spark-producing equipment. A compartment must have openings of at least 1.7 square inches (11 square centimetres) at the top and bottom for ventilation of battery gasses. It should be mounted such that spills and leaks will not drip acid on fuel lines, wiring and other equipment that could be damaged.

⚠️WARNING *Arcing can ignite the explosive hydrogen gas given off by the battery, causing severe personal injury. The battery compartment must be ventilated and must isolate the battery from spark-producing equipment.*

Battery Cables

Size battery cables according to Table 2. The current path between the genset and the negative (-) battery terminal must also be able to carry full cranking current without causing excessive voltage drop. It is highly recommended that a full-length cable be used to connect the genset to the negative (-) battery terminal (Figure 15). Note also that codes may require bonding conductors from the genset and the battery to the vehicle frame.

If a full-length negative (-) cable is not run from the battery (Figure 16), all vehicle frame members in the path of battery cranking currents must have substantial crosssections. The electrical resistance of riveted or bolted frame joints must also be carefully considered, especially if the joints will be exposed to corrosive conditions. A cable must be used to connect the frame to the designated negative (-) terminal on the genset (Figure 16). The cable must be sized according to Table 2. **The genset mounting bolts are not considered adequate means for bonding the genset to the vehicle frame, either for the purpose of carrying cranking currents or for complying with requirements for genset/system grounding.**

Route battery cables away from fuel lines and hot engine exhaust components. Battery cables should be accessible for inspection and replacement, protected from damage and secured to prevent chafing due to vibration.

⚠ WARNING *Routing battery cables with fuel lines can lead to fire and severe personal injury or death. Keep battery cables away from fuel lines.*

Terminate the battery cables with appropriately sized eyelet connectors and connect them to the genset as shown in Figure 17.

TABLE 2. BATTERY CABLE SIZES FOR TEMPERATURES DOWN TO -20° F (-29° C)

TOTAL CABLE LENGTH* FEET (METERS)	CABLE SIZE AWG
0 to 10 (0 to 3)	2**
11 to 15 (3 to 4.5)	0
16 to 20 (4.5 to 6)	000

* - Add the negative battery cable lengths with the positive battery cable lengths for the total.
 ** - A total length of up to 20 feet (6 meters) may be used in warmer climates or when battery capacity totals at least 1000 CCA (Cold Cranking Amps).

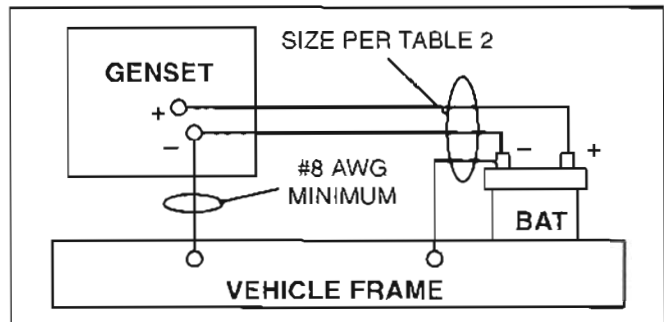

FIGURE 15. FULL-LENGTH CABLE FROM BATTERY NEGATIVE (-) TERMINAL

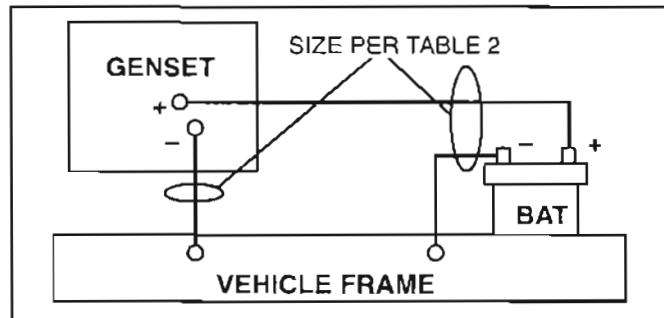

FIGURE 16. VEHICLE FRAME AS PATH FROM BATTERY NEGATIVE (-) TERMINAL

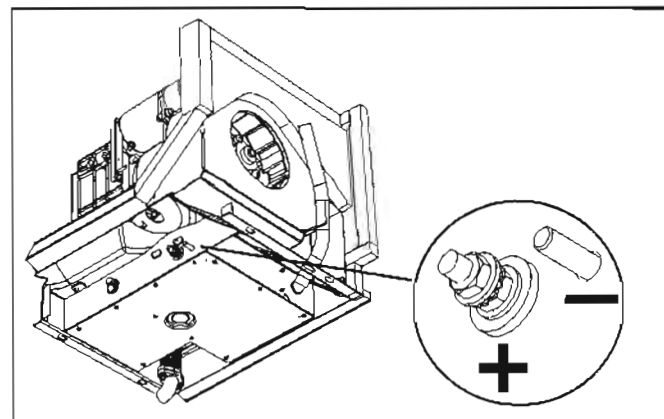

FIGURE 17. BATTERY CABLE CONNECTIONS

Specifications

GENERATOR: 2-Pole Revolving Field, Self-Excited, 1-Phase, Electronically Regulated		
Power	2800 watts	2800 watts
Frequency	60 Hertz*	60 Hertz
Voltage	120 volts	100 volts
Current	23.3 amperes	28 amperes
Speed	3600 rpm	3600 rpm
FUEL CONSUMPTION:		
	Gasoline	Gasoline
No load	0.16 gph (0.6 l/h)	0.16 gph (0.6 l/h)
Half load	0.28 gph (1.1 l/h)	0.28 gph (1.1 l/h)
Full load	0.46 gph (1.7 l/h)	0.46 gph (1.7 l/h)
ENGINE: 1-Cylinder, 4-Stroke Cycle, Spark-Ignited, OHV, Air Cooled, Mechanically Governed		
Bore	2.64 inch (67 mm)	2.64 inch (67 mm)
Stroke	2.2 inch (56 mm)	2.2 inch (56 mm)
Displacement	12 inch ³ (197 cc)	12 inch ³ (197 cc)
Compression Ratio	8.5 : 1	8.5 : 1
Oil Capacity	1 quart (0.95 l)	1 quart (0.95 l)
Intake Valve Lash (Cold)	0.002 inch (0.05 mm)	0.002 inch (0.05 mm)
Exhaust Valve Lash (Cold)	0.002 inch (0.05 mm)	0.002 inch (0.05 mm)
Spark Plug Gap	0.025 inch (0.64 mm)	0.025 inch (0.64 mm)
Spark Plug Tightening Torque	13 lbs-ft (17 N-m)	13 lbs-ft (17 N-m)
Ignition Timing (magneto type ignition)	25° BTDC, non-adjustable	25° BTDC, non-adjustable
DC SYSTEM:		
Nominal Battery Voltage	12 volts	12 volts
Min. Battery Rating: Cold Cranking Amps (CCA) @ 0° F (-18° C)	360/450 above/below 32° F (0° C)	360/450 above/below 32° F (0° C)
Control Fuse	5 amperes	5 amperes
INSTALLATION:		
Weight of Genset (with engine oil)	100 lbs (45 kg)	
Minimum Compartment Size (H x D x W)**	15.5 inch x 17.5 inch x 20.2 inch (394 mm x 445 mm x 512 mm)	
Minimum Free Air Inlet Area	40 inch ² (258 cm ²)	
Muffler Outlet Collar O. D.	1.13 inch	
Fuel Connection	1/4 inch barb fitting for gasoline hose	
* Listed by CSA and the U. S. Testing Company.		
** See the Installation Manual for additional considerations when sizing the genset compartment.		

Installation Review and Startup

INSTALLATION REVIEW

Before starting the genset inspect the installation and check (✓) each of the following questions if it can be answered "YES". If an item cannot be checked provision must be made to satisfy the requirement.

- [] Is the control panel on the genset easily accessible for starting and stopping the genset and resetting the circuit breaker?
- [] Is there easy access for checking and adding engine oil, replacing the spark plug and changing the air filter?
- [] Is the genset securely bolted in place?
- [] Are all specified clearances provided?
- [] Are the air inlet and outlet openings free of obstructions?
- [] Is there access for draining engine oil?
- [] Are all tailpipe connections tight and all hangers and support straps secure?
- [] Does the tailpipe terminate at least 1 inch (25 mm) beyond the perimeter of the vehicle and at least 6 inches (153 mm) away from any opening into the vehicle?
- [] Is the genset located outside the vehicle interior or separated by approved vapor-tight and fire-resistant materials?
- [] Are all openings into the vehicle, such as for AC wiring, sealed to keep out engine exhaust? Are AC conduit connectors sealed inside and outside?
- [] Have all AC connections been inspected and approved?
- [] Has a properly sized battery(ies) been installed in a ventilated compartment isolated from the genset?

- [] Have properly sized battery cables been installed and secured at sufficient intervals to prevent chaffing and contact with sharp edges, fuel lines and hot exhaust parts?
- [] Are all fuel connections tight?
- [] Has the fuel line been secured at sufficient intervals to prevent chaffing and contact with sharp edges, electrical wiring and hot exhaust parts?

STARTUP

When all the items on the Installation Review check list have been checked, connect the battery cables to the battery, positive (+) cable first.

⚠WARNING *Batteries give off explosive gases that can cause severe personal injury. Do not smoke near batteries. Keep flames, sparks, pilot lights, electrical arcs and arc-producing equipment and all other ignition sources well away.*

Read the Operator's Manual and perform the maintenance and pre-start checks instructed. The genset is shipped from the factory with the proper level of engine oil, which should nevertheless be checked before the genset is started. Start and operate the genset, following all the instructions and safety precautions in the Operator's Manual.

⚠WARNING *EXHAUST GAS IS DEADLY! Do not operate the genset when the vehicle is indoors or where exhaust can accumulate.*

Check for fuel and exhaust leaks and unusual noises while the genset is running under full and intermediate loads. Do not place the genset in service until all fuel and exhaust leaks have been fixed and operation is satisfactory.

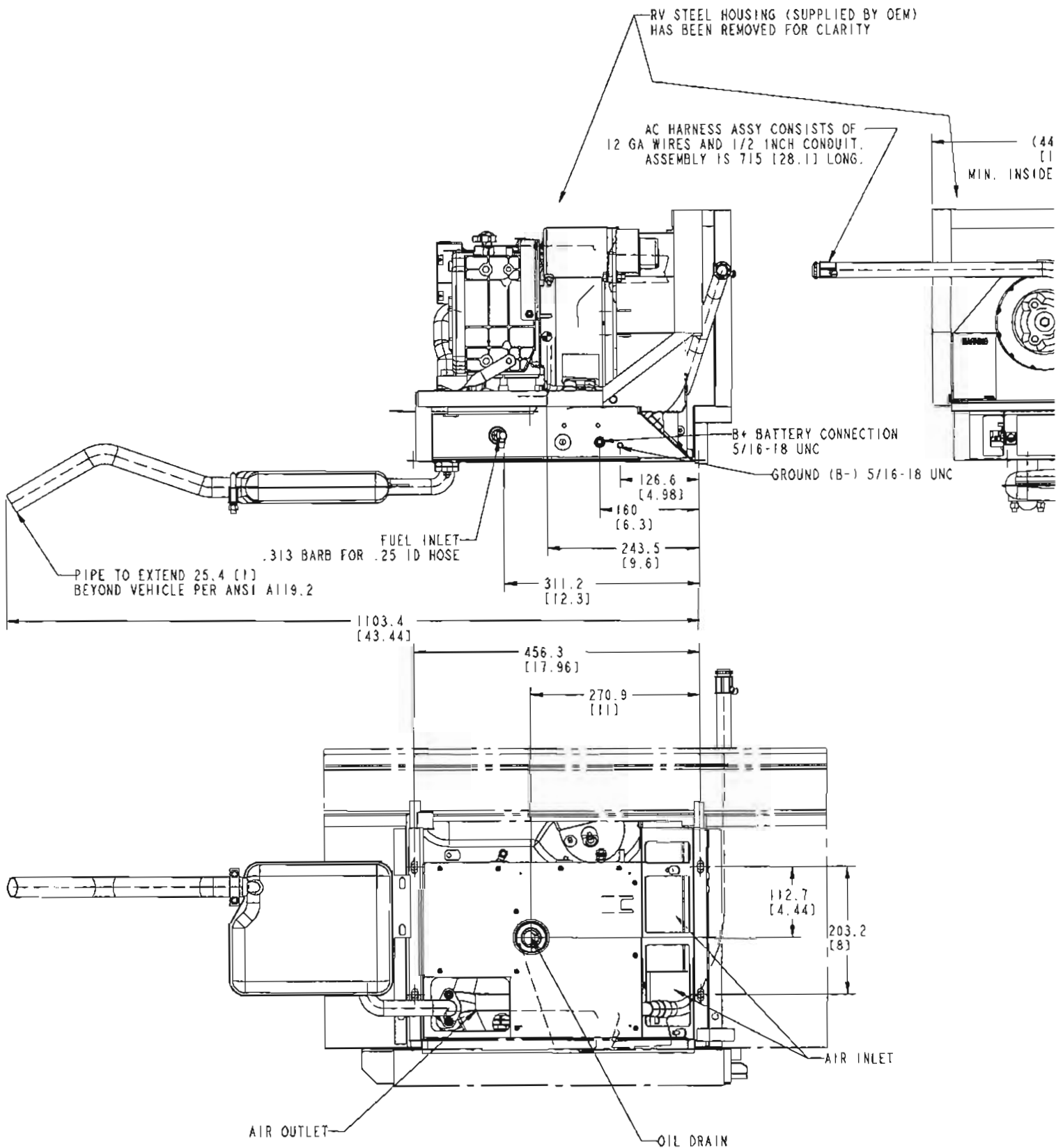

GENSET OUTLIN

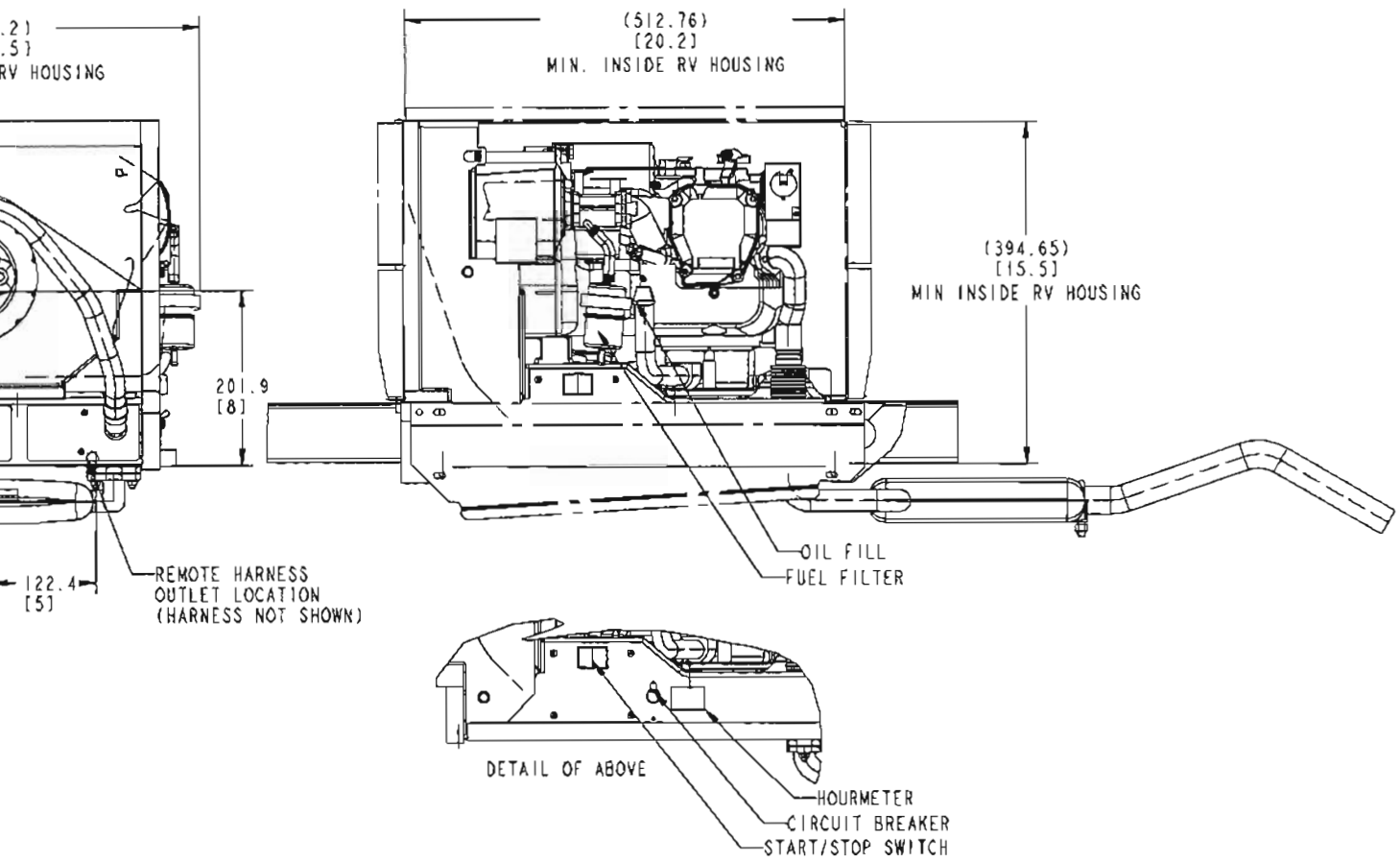

NOTE:

1. PRIMARY DIMENSIONS ARE MILLIMETERS. DIMENSIONS IN [] ARE INCHES
2. RV COMPARTMENT SHALL ALLOW OPENING AND CLOSING RV ACCESS TO THE FOLLOWING COMPONENTS:
START/STOP SWITCH, CIRCUIT BREAKER, OIL CHECK/FILL AND DRAIN
3. UNIT WEIGHT 45 KG (100 LBS)
4. PHANTOM OUTLINE OF RV HOUSING SHOWN FOR REFERENCE, NOT INCLUDED WITH GENSET.

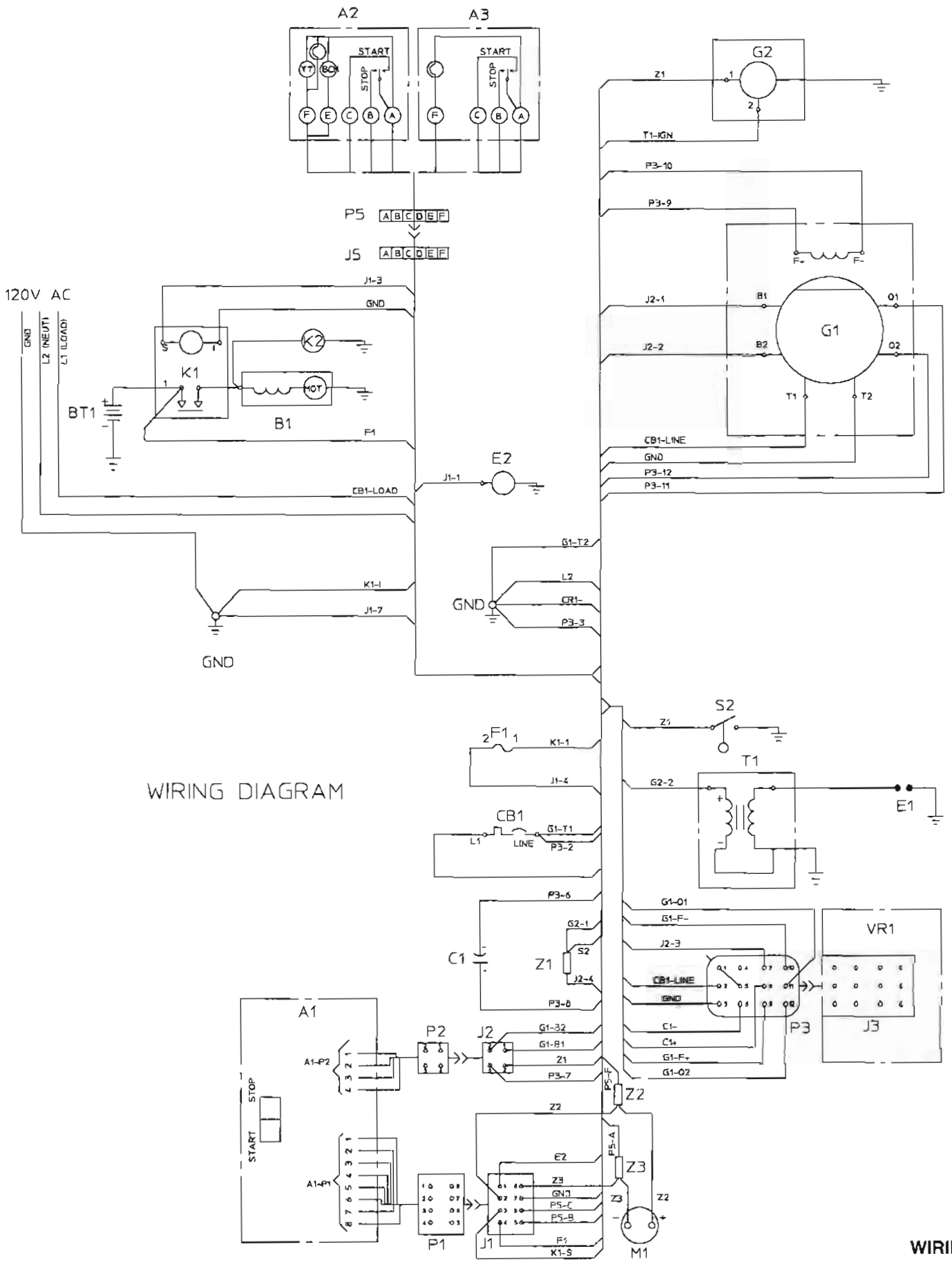

WIRING DIAGRAM

WIRING DIA

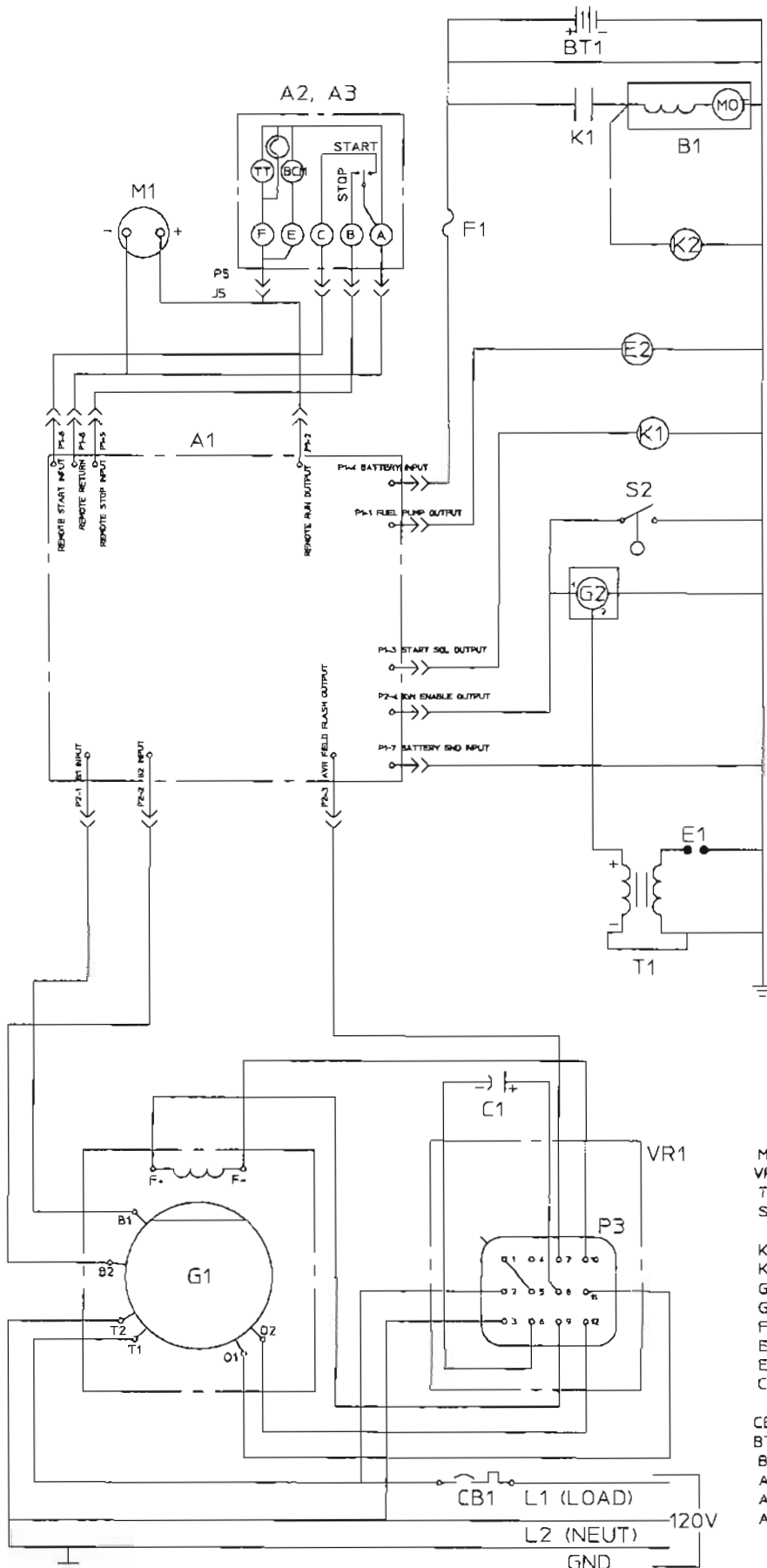

- M1 | METER-TIME TOTALIZING
- VR1 | REGULATOR-VOLTAGE
- T1 | COIL-IGNITION
- S2 | SWITCH-LOW OIL LEVEL

- K2 | SOL-REGULATOR LP
- K1 | RELAY-STARTER
- G2 | MAGNETO-IGNITION
- G1 | GENERATOR
- F1 | FUSE
- E2 | FUEL PUMP (FUEL SOL - LP)
- E1 | SPARK PLUG
- C1 | CAPACITOR

- CB1 | CIRCUIT BREAKER (AC OUTPUT)
- BT1 | BATTERY 12V
- B1 | MOTOR-STARTER
- A3 | REMOTE CONTROL-STANDARD
- A2 | REMOTE CONTROL-DELUXE
- A1 | CONTROL ASSY

SCHMATIC

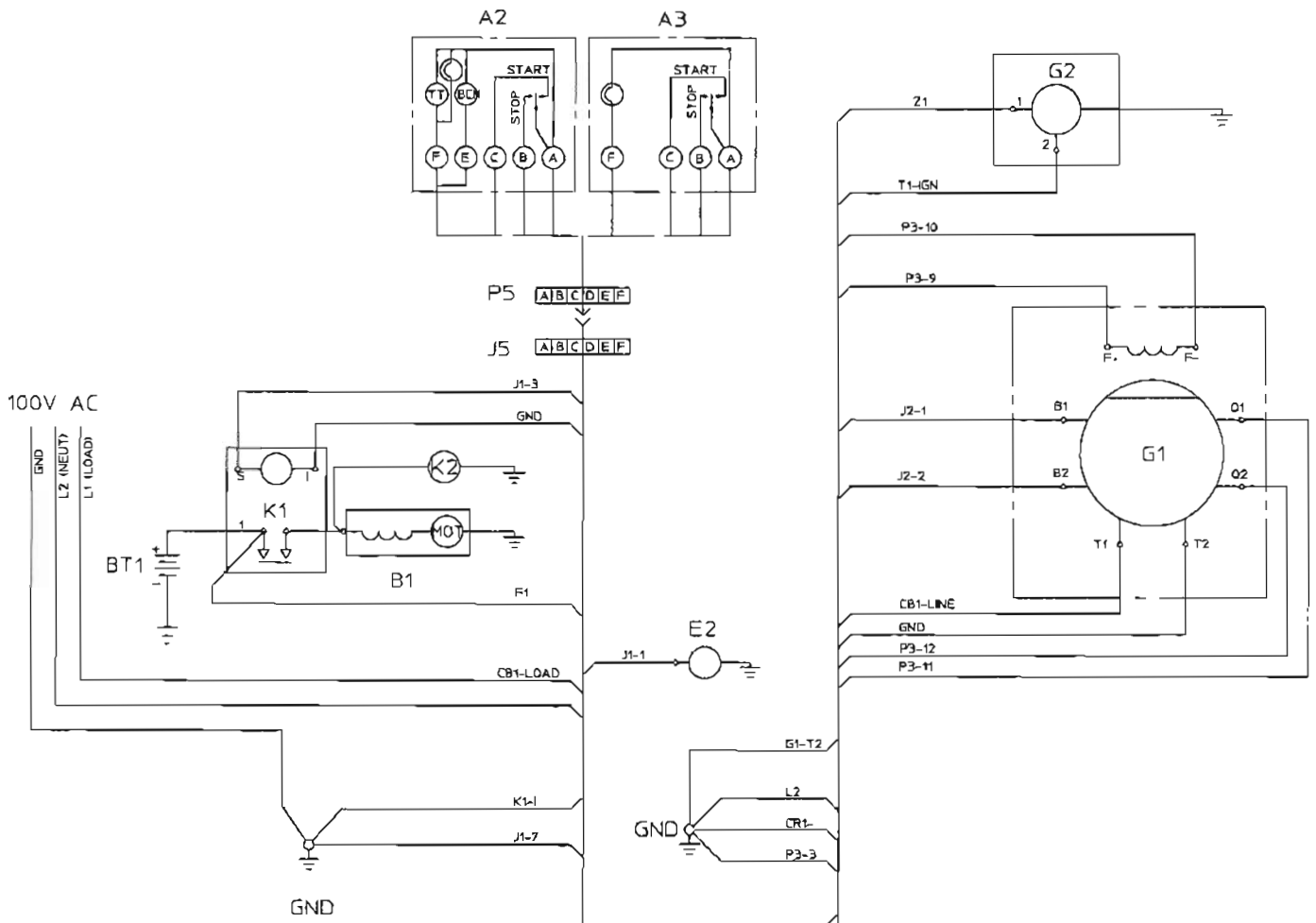

WIRING DIAGRAM

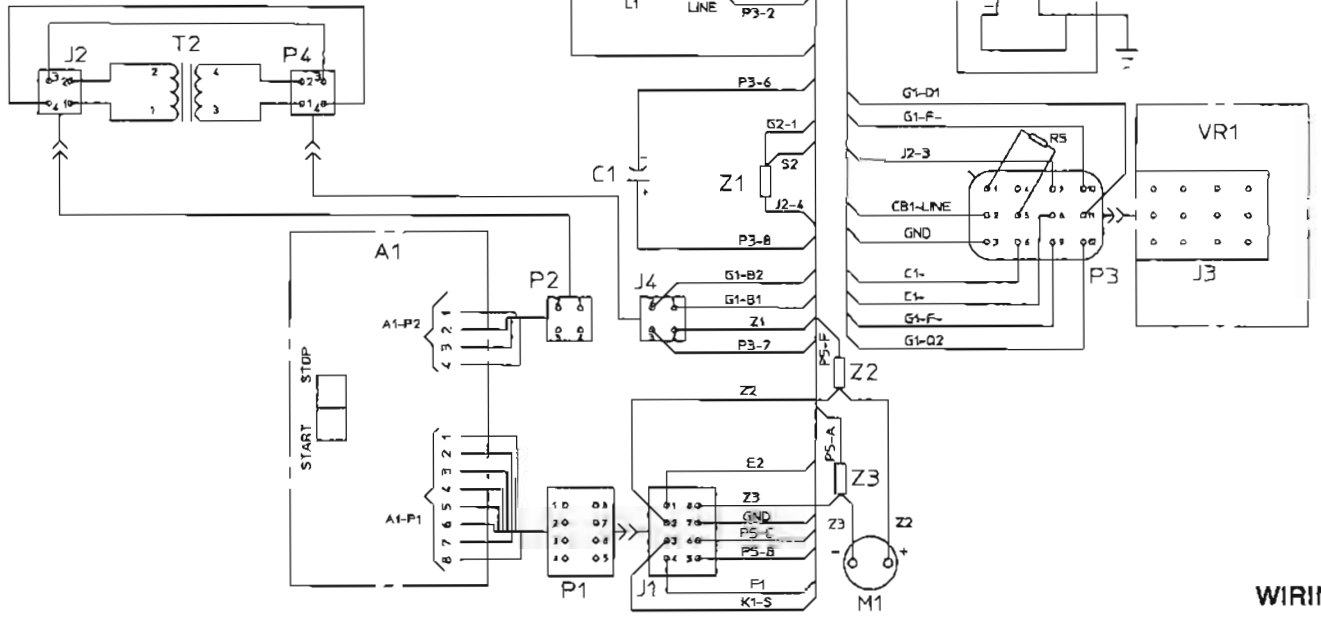

WIRING DIAGRAM

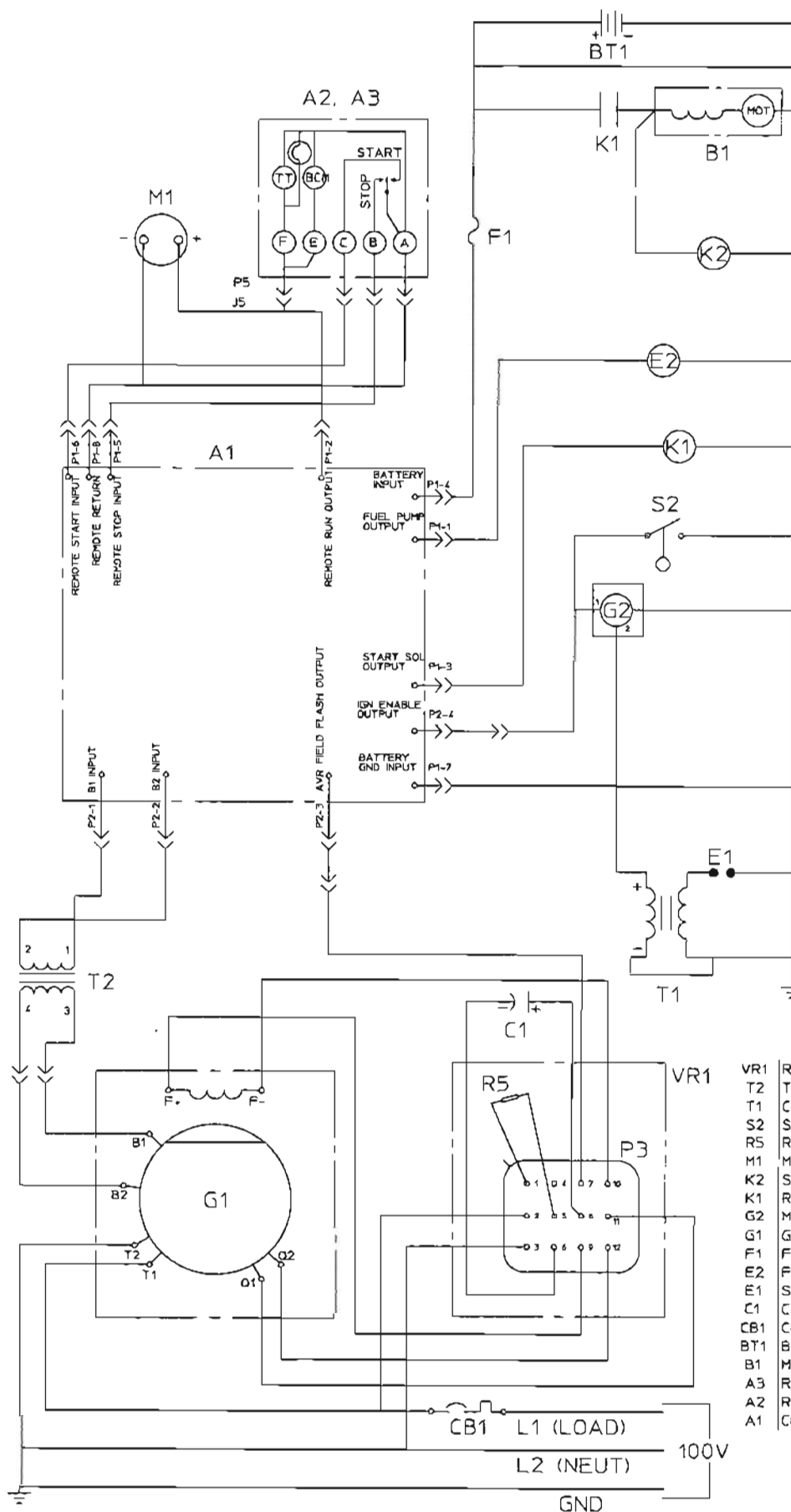

- VR1 REGULATOR-VOLTAGE
- T2 TRANSFORMER-STEPUP
- T1 COIL-IGNITION
- S2 SWITCH-LOW OIL LEVEL
- R5 RESISTOR ASSY-FIXED
- M1 METER-TIME TOTALIZING
- K2 SOL-REGULATOR LP
- K1 RELAY-STARTER
- G2 MAGNETO-IGNITION
- G1 GENERATOR
- F1 FUSE
- E2 FUEL PUMP (FUEL SOL - LP)
- E1 SPARK PLUG
- C1 CAPACITOR
- CB1 CIRCUIT BREAKER (AC OUTPUT)
- BT1 BATTERY 12V
- B1 MOTOR-STARTER
- A3 REMOTE CONTROL-STANDARD
- A2 REMOTE CONTROL-DELUXE
- A1 CONTROL ASSY

SCHMATIC



Cummins Power Generation
1400 73rd Avenue N E.
Minneapolis, MN 55432
763-574-5000
Fax: 763-528-7229

Cummins and Onan are registered trademarks of Cummins Inc.