

SUSPENSION - REAR

1995-97SUSPENSION Volkswagen Suspension - Rear

DESCRIPTION

Suspension uses control arms and axle beam for stabilization. Control arms and axle beam are combined as one unit. Brake drums or discs rotate on stub axles bolted to control arms. See **Fig. 1**.

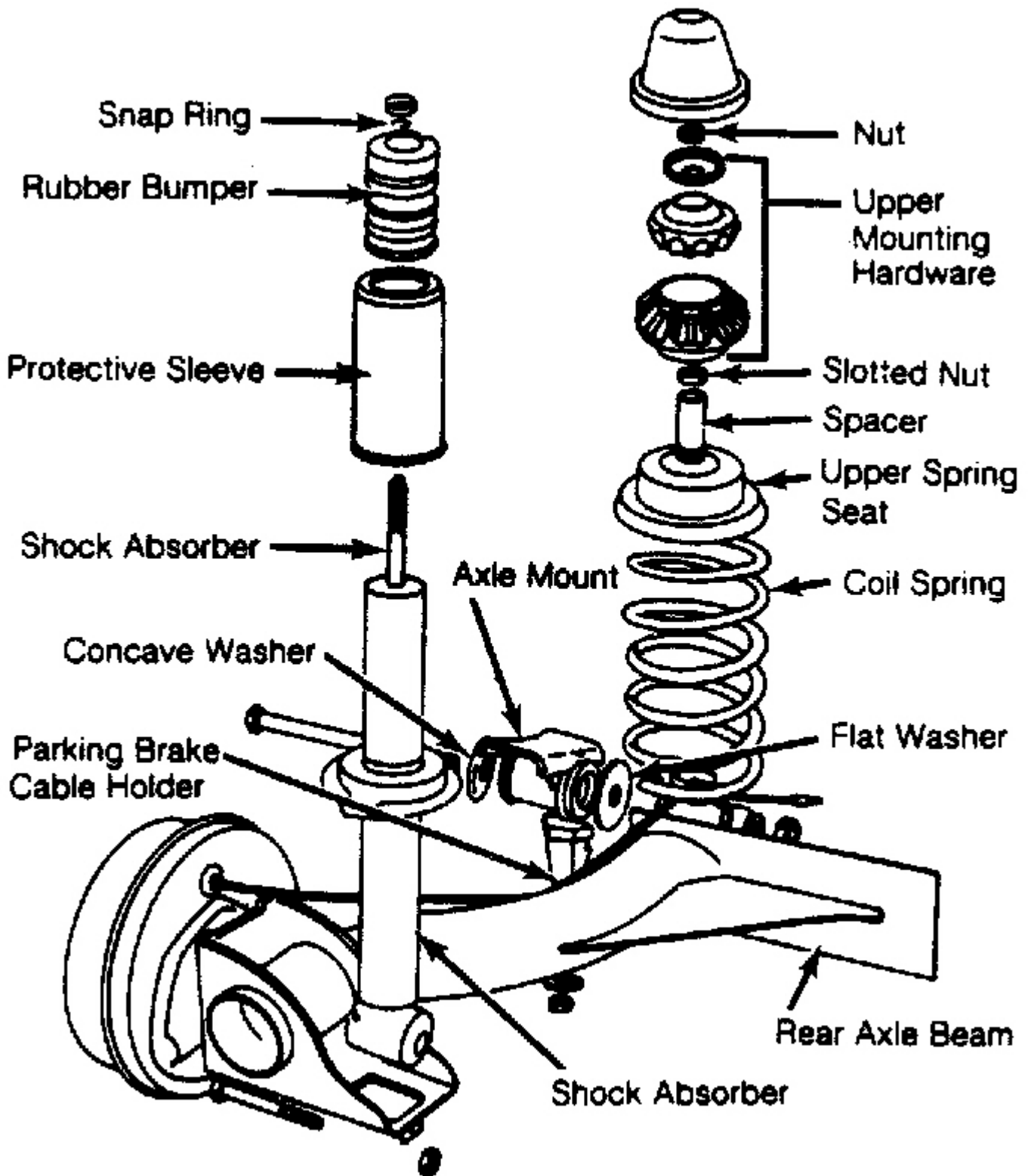

Fig. 1: Identifying Rear Suspension Components (Typical)
 Courtesy of VOLKSWAGEN UNITED STATES, INC.

ADJUSTMENTS & INSPECTION

WHEEL ALIGNMENT SPECIFICATIONS & PROCEDURES

NOTE: See **WHEEL ALIGNMENT SPECIFICATIONS & PROCEDURES** article in **WHEEL ALIGNMENT** section.

WHEEL BEARING

Tighten hub nut to 148 ft. lbs. (200 N.m). Insert tip of screwdriver between thrust washer and hub. Adjustment is correct when light finger pressure against screwdriver moves thrust washer. Turn hub nut to adjust. Install NEW cotter pin.

REMOVAL & INSTALLATION

STRUT/SHOCK ABSORBER

CAUTION: DO NOT remove both suspension strut/shock absorbers at same time.

Removal

1. With vehicle on floor, remove plastic cap which covers upper strut/shock retaining nuts. Remove strut/shock retaining nuts. Slowly raise vehicle until weight is off spring. Remove bolt which retains lower end of strut/shock absorber to axle beam mount. Raise vehicle until strut/shock can be removed. Place strut/shock assembly in vise.
2. Hold piston rod. Remove strut/shock retaining nut and related components. See **Fig. 1** . Remove slotted nut (some models). Remove spacer and coil spring. If coil spring is to be replaced, ensure paint stripe color on replacement spring matches original spring color stripe.

Installation

1. Install protective cap and tube onto shock absorber. Install rubber buffer with small end downward. Install snap ring and washer. Place spring into lower seat. Install upper retainer with spacer sleeve.
2. Tighten slotted nut (some models) which retains piston rod. Install upper mounting hardware. Tighten piston rod. To complete installation, reverse removal procedure. Tighten bolts and nuts to specification. See **TORQUE SPECIFICATIONS**.

SUSPENSION ASSEMBLY

CAUTION: When removing suspension assembly, add weight to rear of vehicle to prevent tipping due to change in center of gravity.

Removal

1. With vehicle on floor, disconnect upper strut/shock mount. Raise and support vehicle. Disconnect parking brake at bracket near axle mount.
2. Disconnect and plug brakelines. Leave flex hose attached to suspension. Separate brake pressure regulator spring from axle beam (if equipped). Remove nuts which retain axle beam to body.

NOTE: DO NOT install bolts and nuts fouled with undercoating. With waxy coating on threads, true tightening torque cannot be measured. Clean or replace bolts and nuts.

Installation

1. If axle beam mounting has been removed, adjust mounting pad. See **Fig. 2** . If pad is not correctly aligned, torsional preload of mounting bushings will be incorrect.
2. Position rear suspension on body. Install nuts retaining axle beam to body. Raise wheel. Guide upper end of strut/shock into body mount.
3. Connect parking brake cables. Connect brakelines. Lower vehicle. Tighten upper strut/shock retaining nuts. Tighten all bolts and nuts to specification. See **TORQUE SPECIFICATIONS**. Bleed brake system.

Align Mounting Surface "A"
With Imaginary Line "B".
Tighten Pivot Bolt "C" To
43 Ft. Lbs. (58 N.m).

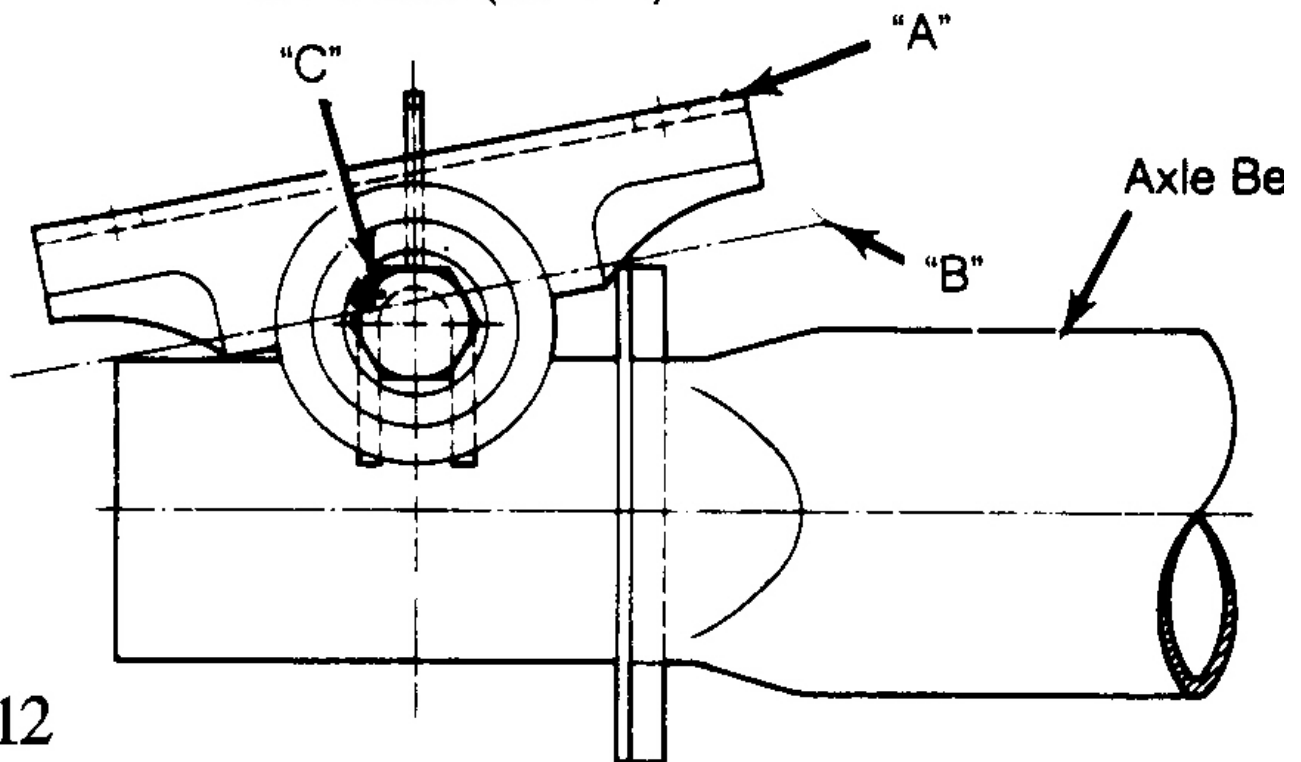

52512

Fig. 2: Aligning Axle Beam Mounting Pad
Courtesy of VOLKSWAGEN UNITED STATES, INC.

WHEEL BEARING

Removal (Disc Brakes)

Raise and support vehicle. Remove wheel assembly. Remove caliper assembly and support it out of work area. Remove dust cap, cotter pin, hub nut, and thrust washer. Remove brake disc. Using a long drift, tap bearings, races, and grease seal from disc hub.

Installation

1. Clean hub cavity thoroughly. Using Bearing Race Installer (VW 432 and VW 411), press inner and outer bearing races into bore. Lubricate and install inner bearing. Using Seal Installer (VW 295 and 3074), tap grease seal into bore.

2. Install brake disc, outer bearing, thrust washer, and hub nut. Reverse removal procedure to complete installation. Adjust wheel bearing. See WHEEL BEARING under ADJUSTMENTS & INSPECTION. Install NEW cotter pin.

Removal (Drum Brakes)

Raise and support vehicle. Remove wheel assembly. Using transaxle jack, support transaxle. Remove brake drum. Using a Hub Puller (3253), remove hub from control arm. Remove circlip. Using a Bearing Puller (40-105), remove wheel bearing from control arm. See **Fig. 3**.

Installation

To install, reverse removal procedure. Clean hub cavity thoroughly. Lubricate and install inner bearing. Tighten all bolts and nuts to specification. See TORQUE SPECIFICATIONS.

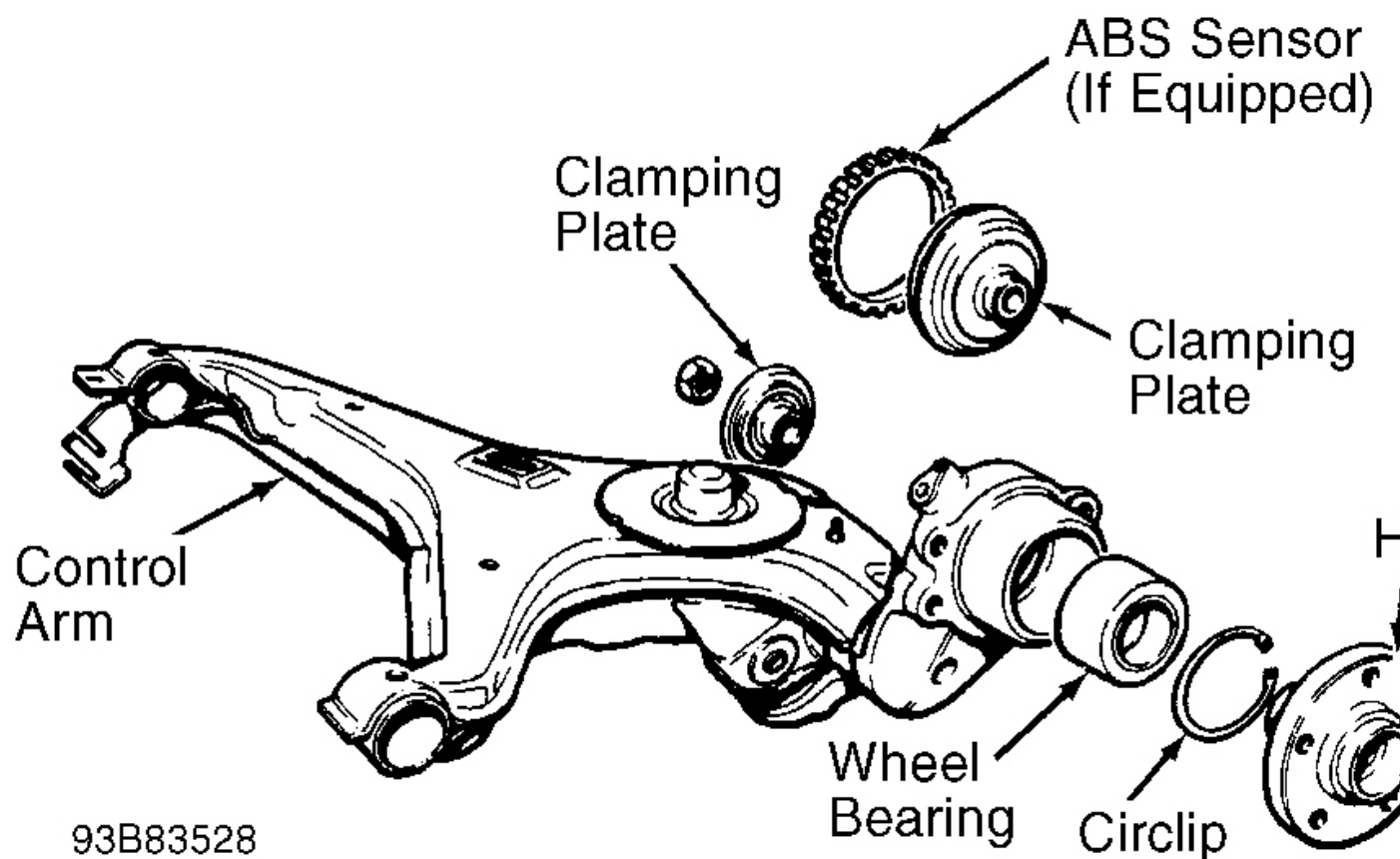

Fig. 3: Identifying Hub & Wheel Bearing Components (EuroVan)
 Courtesy of VOLKSWAGEN UNITED STATES, INC.

TORQUE SPECIFICATIONS

TORQUE SPECIFICATIONS

Application	Ft. Lbs. (N.m)
Brake Backing Plate Bolt	110 (150)
Rear Axle CV Joint Bolt	148 (200)
Rear Axle Inner Bushing Bolt	80 (100)
Rear Axle Outer Bushing Bolt	118 (160)

1996 Volkswagen EuroVan CV

SUSPENSION - REAR

Shock Absorber Lower Bolt	33 (45)
Shock Absorber Upper Bolt	74 (100)
Wheel Lug Bolt	81 (110)