

1995-96 SUSPENSION**Front - EuroVan****DESCRIPTION**

FWD independent suspension is an double-wishbone type with torsion bars mounted on upper control arm. Wheel is supported by a steering knuckle mounted between the upper and lower control arms. Torsion bars are mounted between the upper control arms and vehicle frame. Shock absorbers are mounted between the lower control arm and frame. See **Fig. 1**.

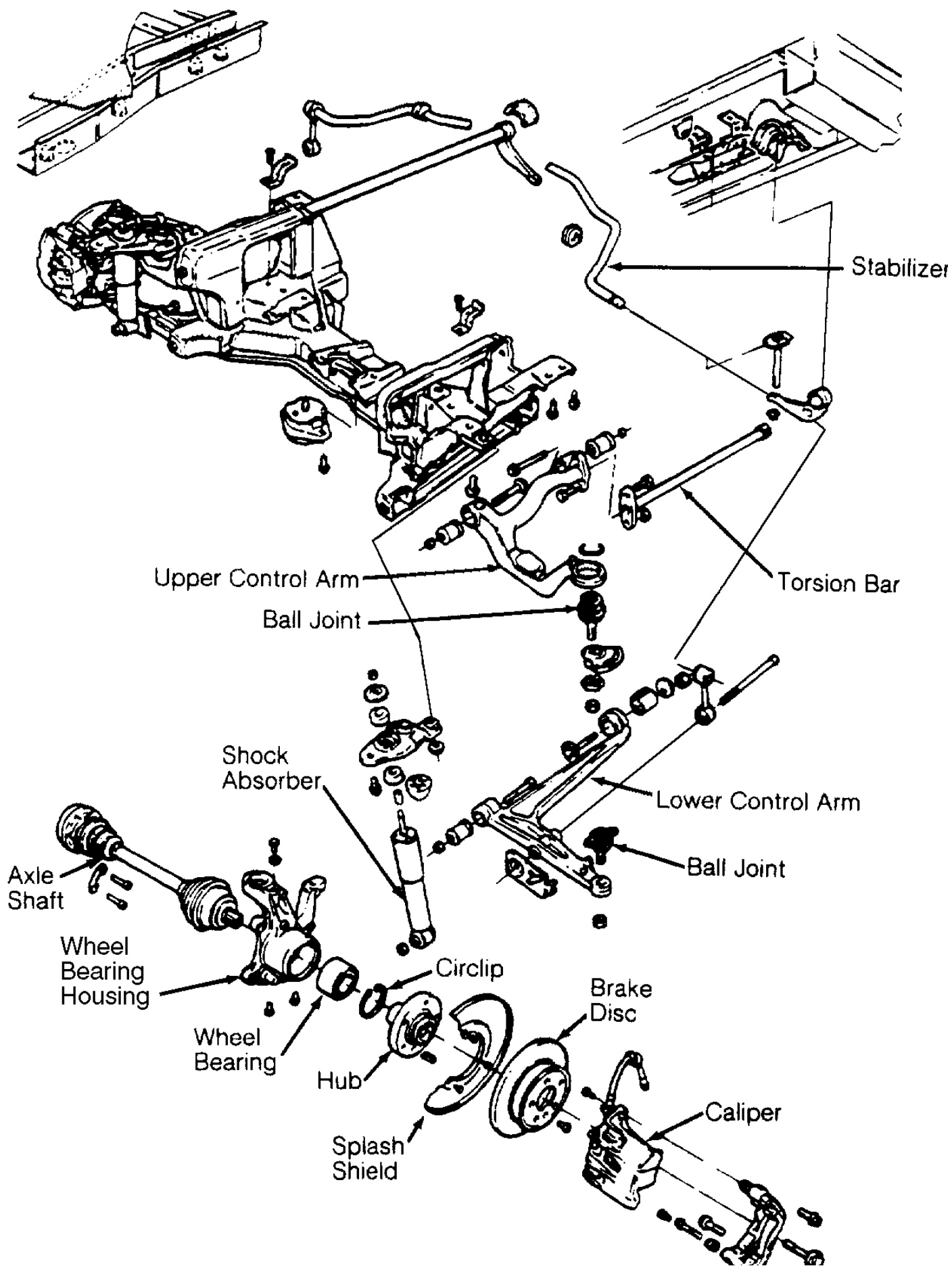

Fig. 1: Exploded View Of Front Suspension

Courtesy of VOLKSWAGEN UNITED STATES, INC.

ADJUSTMENTS & INSPECTION**WHEEL ALIGNMENT SPECIFICATIONS & PROCEDURES**

NOTE: See **WHEEL ALIGNMENT SPECIFICATIONS & PROCEDURES** article in the **WHEEL ALIGNMENT** section.

WHEEL BEARING

No adjustment is required.

RIDING HEIGHT

Measure the distance between bolt head of upper shock absorber mounting and center of bolt head of lower shock absorber mounting. If distance measured is not 10.3-10.4" (263-265 mm) turn torsion bar adjustment bolt until correct riding height is obtained.

BALL JOINT CHECKING

Raise and support vehicle. Inspect ball joints for excessive play and damaged rubber boots. There should be no vertical or horizontal ball joint play. Replace ball joint if any play is present.

REMOVAL & INSTALLATION**BALL JOINTS****Removal (Lower Ball Joint)**

1. Install Control Arm Support (3250) between upper control arm and subframe. See **Fig. 5** . If control arm support is not available, release tension from torsion bar. Raise and support vehicle.
2. Remove steering knuckle. See **WHEEL BEARING** under **REMOVAL & INSTALLATION**. Using puller, remove lower ball joint from lower control arm. See **Fig. 2** .

Installation

To install, reverse removal procedure. Ensure all nuts and bolts are tightened to specification. See **TORQUE SPECIFICATIONS**.

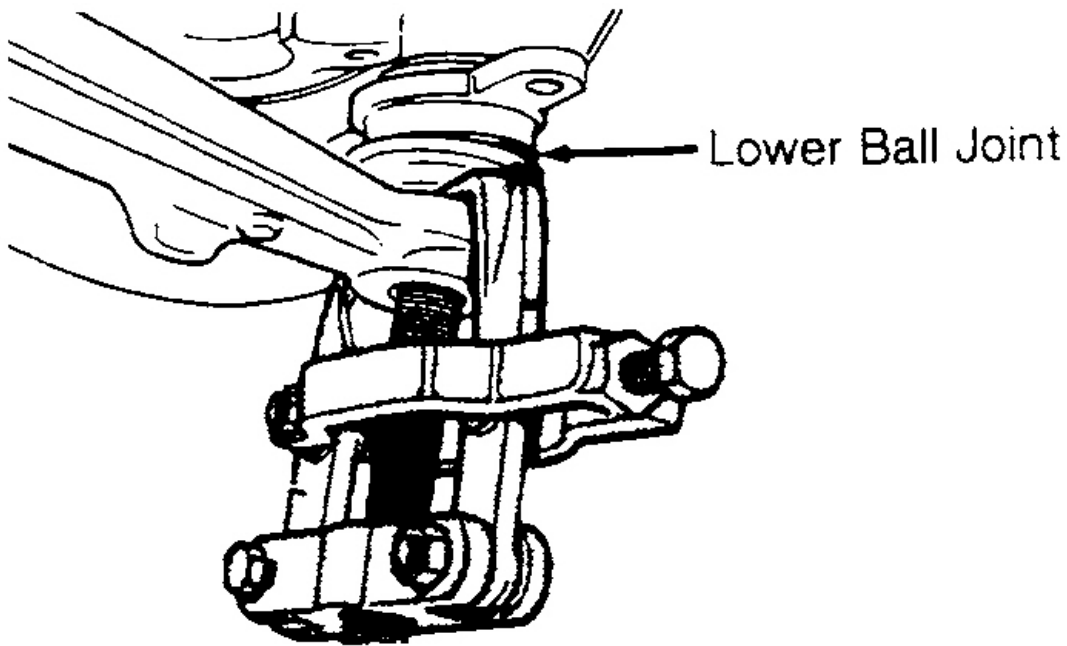

G93D83512

Fig. 2: Removing Lower Ball Joint

Courtesy of VOLKSWAGEN UNITED STATES, INC.

Removal (Upper Ball Joint)

1. Install Control Arm Support (3250) between upper control arm and subframe. See **Fig. 5** . If control arm support is not available, release tension from torsion bar. Raise and support vehicle.
2. Remove steering knuckle. See WHEEL BEARING under REMOVAL & INSTALLATION. Remove eccentric bushing. See **Fig. 7** . Using ball joint puller, remove upper ball joint from upper control arm. See **Fig. 3** .

Installation

Using Press (3111), install upper ball joint into upper control arm. See **Fig. 4** . Reverse removal procedure to complete installation. Ensure all nuts and bolts are tightened to specification. See TORQUE SPECIFICATIONS.

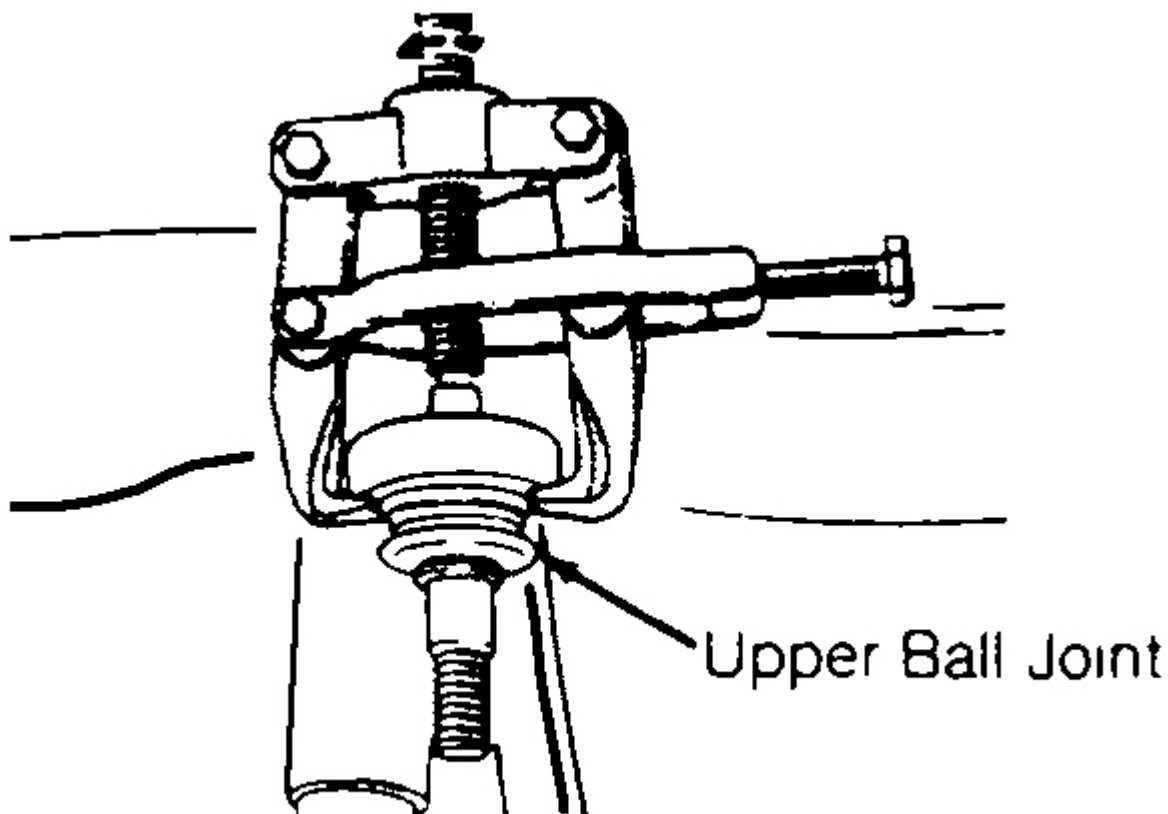

G93E83513

Fig. 3: Removing Upper Ball Joint

Courtesy of VOLKSWAGEN UNITED STATES, INC.

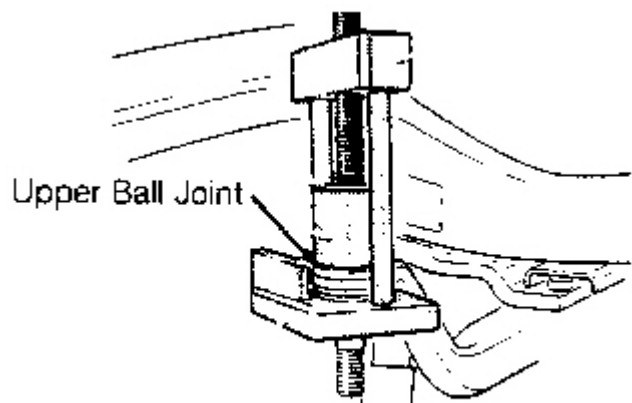

93F83514

Fig. 4: Installing Upper Ball Joint

Courtesy of VOLKSWAGEN UNITED STATES, INC.

HUB & KNUCKLE ASSEMBLY

Use exploded view illustration when removing or installing hub and knuckle assembly. See **Fig. 1**.

LOWER CONTROL ARM

Removal

1. Install Control Arm Support (3250) between upper control arm and subframe. See **Fig. 5** . If control arm support is not available, release tension from torsion bar. Raise and support vehicle.
2. Remove bolt retaining ball joint at steering knuckle. Separate ball joint from housing. Leave control arm hanging in mounts at subframe. If control arm is not to be removed and ball joint is riveted to control arm, drill out ball joint rivets using a 9/32" (7 mm) drill. If ball joint is bolted to control arm, remove bolts. Remove ball joint.
3. If control arm is to be removed from vehicle, remove stabilizer bar link rod nut, washers, and bushings. See **Fig. 6** . Remove pivot bolt and bracket housing inner pivot pin. Slide out control arm.

Inspection

Check lower control arm bushings for excessive wear, cracks or contamination. Replace bushings if necessary. To replace bushings, press out worn bushing. Select new bushing and press into position. Ensure bushing does not twist when seating into place.

Installation

1. Slide new ball joint into slot in control arm. Install and tighten ball joint retaining bolts. Install lower control arm to subframe. Install ball joint into steering knuckle. To complete installation, reverse removal procedure.
2. Tighten control arm bolts with vehicle on ground. Tighten all bolts and nuts to specification. See **TORQUE SPECIFICATIONS**. Check wheel alignment. See **WHEEL ALIGNMENT SPECIFICATIONS & PROCEDURES** article in **WHEEL ALIGNMENT** section.

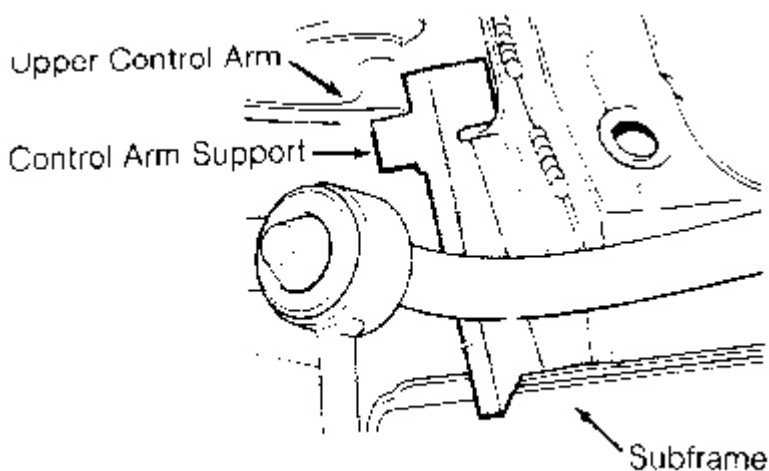

93G83515

Fig. 5: Supporting Upper Control Arm & Torsion Bar
Courtesy of VOLKSWAGEN UNITED STATES, INC.

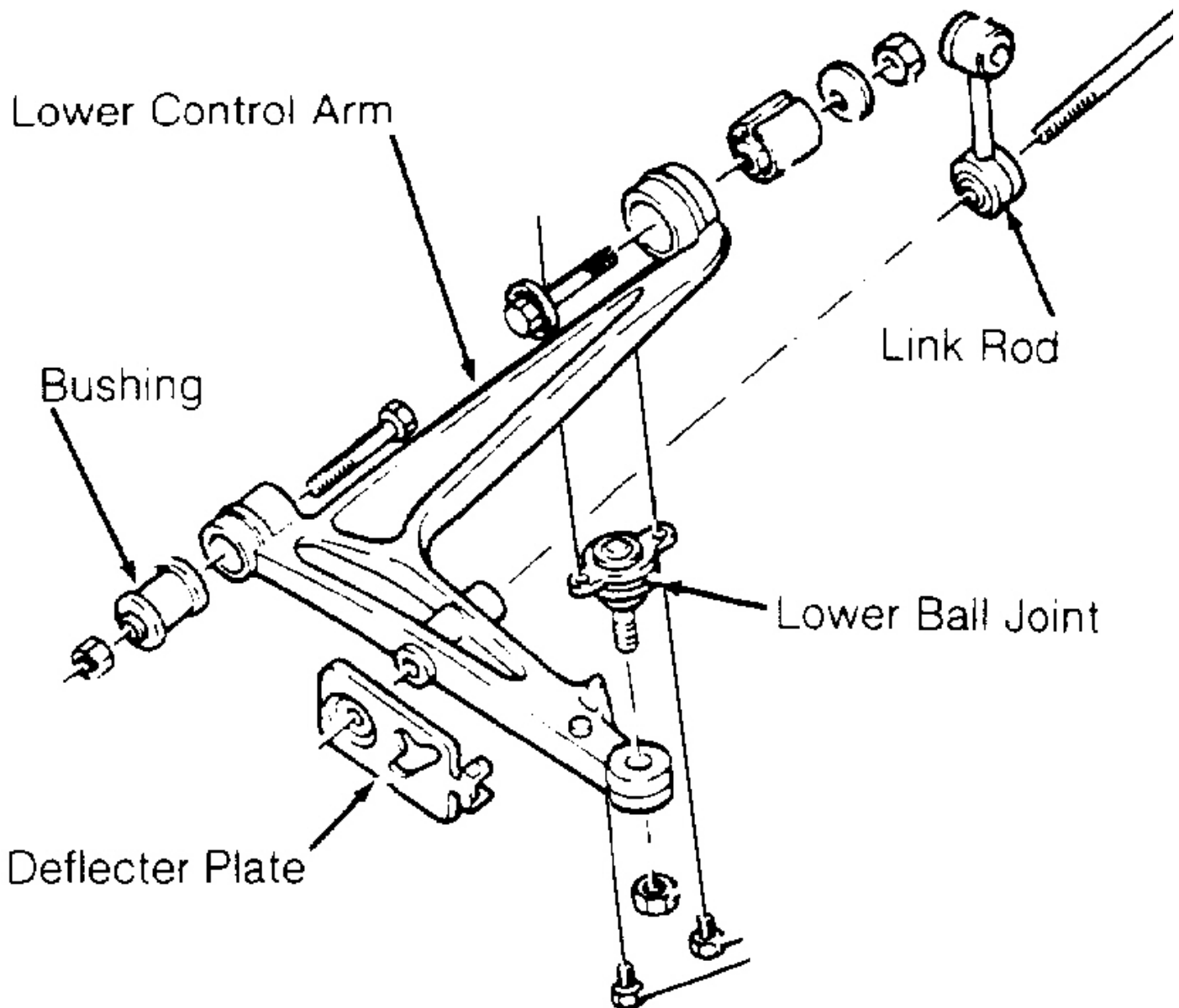

G93H83516

Fig. 6: Exploded View Of Lower Control Arm Assembly
 Courtesy of VOLKSWAGEN UNITED STATES, INC.

SHOCK ABSORBER

Removal & Installation

1. Raise and support vehicle. Remove wheel assembly. Remove nuts retaining shock absorber to bracket. Remove washers and cushions from shaft of shock absorber.
2. Remove nuts and bolts securing shock absorber to lower control arm. Compress shock absorber and remove from vehicle. To install, reverse removal procedure.

TORSION BAR

Removal

Remove fuel tank. Remove exhaust system heat shield. Measure length of torsion bar stud thread below adjustment nut for installation reference. Loosen adjusting nut. Remove bolts attaching torsion bar to upper control arm. Remove torsion bar.

Installation

To install, reverse removal procedure. Tighten adjusting nut so stud protrusion is equal to original measurement.

UPPER CONTROL ARM**Removal**

1. Remove torsion bar. See TORSION BAR under REMOVAL & INSTALLATION. Remove cotter pin and nut. Disconnect upper ball joint from steering knuckle. See **Fig. 7**. Remove nut, cushion and retainer.
2. Disconnect shock absorber from frame. Do not disconnect shock absorber from lower control arm. Remove upper control arm shaft bolts and remove upper control arm from frame.

Bushing Replacement

Using Adapter (VW 519) and a press, remove bushings. Press in new bushing using Adapter (VW 454). Install upper control arm shaft. Press in new front bushing.

Installation

To install, reverse removal procedure. Tighten shaft nuts to specification with vehicle on ground. Tighten all nuts and bolts to specification. See TORQUE SPECIFICATIONS.

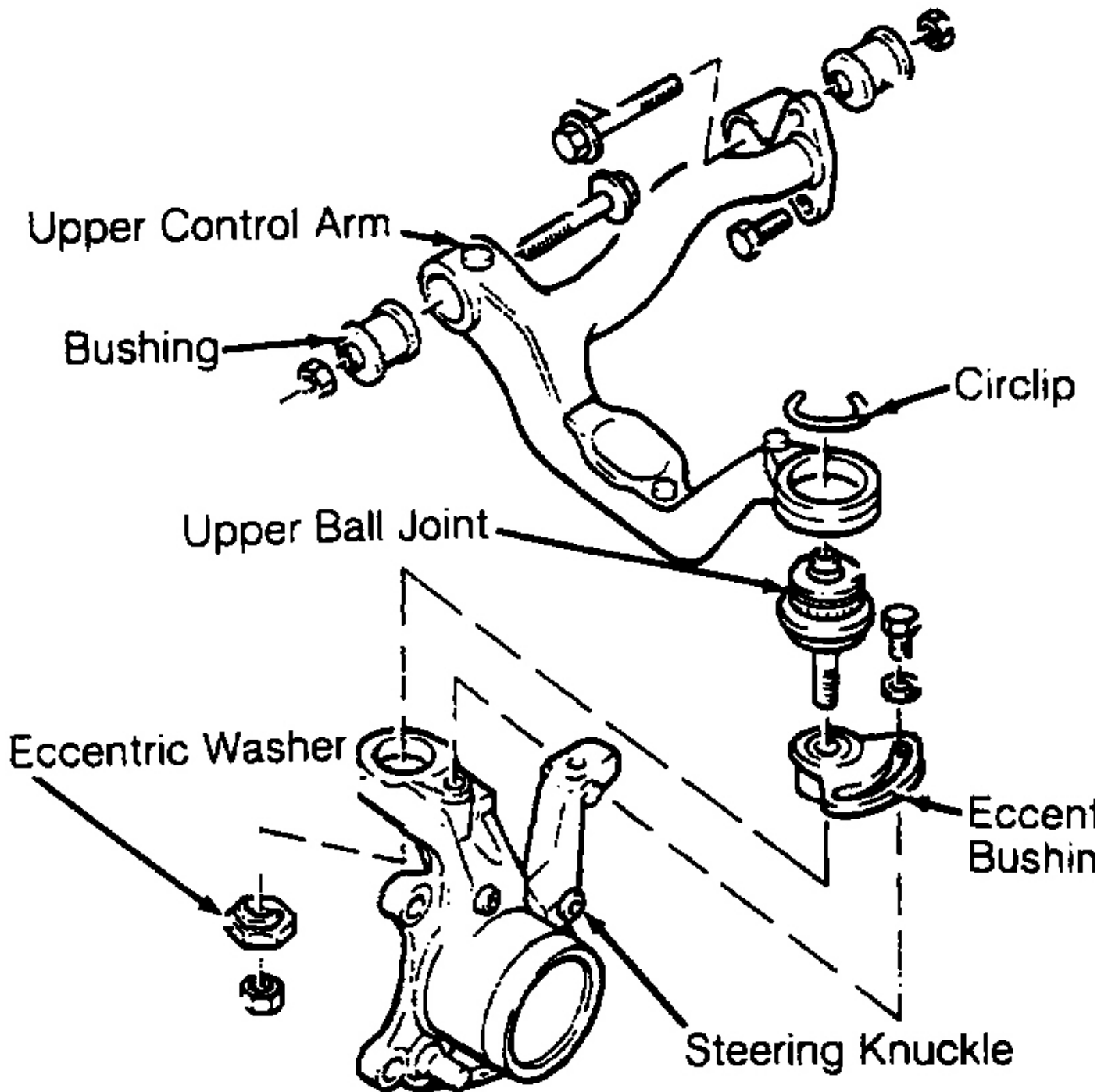

G93183517

Fig. 7: Exploded View Of Upper Control Arm Assembly
 Courtesy of VOLKSWAGEN UNITED STATES, INC.

WHEEL BEARING

Removal

1. Remove axle shaft nut with front wheels on ground. Install Control Arm Support (3250) between upper control arm and subframe. See **Fig. 5** . If control arm support is not available, release tension from torsion bar. Raise and support vehicle.

2. Remove wheel assembly. Remove brake caliper attaching bolts. Remove caliper, and wire aside. Remove brake disc retaining screw and remove disc. Disconnect tie rod ball joint from steering knuckle. Remove control arm ball joint clamp nut and bolt. Disconnect control arm ball joint from steering knuckle. Remove steering knuckle.
3. Remove wheel bearing circlip. Using Hub Remover (40-105), press wheel hub assembly out of steering knuckle. See **Fig. 8** . Using Bearing Remover (VW 442), press wheel bearing out of steering knuckle. See **Fig. 9** . Using a bearing puller, remove wheel bearing inner race from hub assembly. See **Fig. 10** .

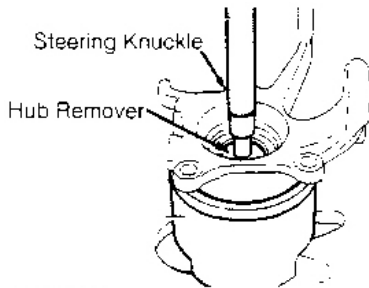

93J83518

Fig. 8: Pressing Hub Assembly Out Of Steering Knuckle
 Courtesy of VOLKSWAGEN UNITED STATES, INC.

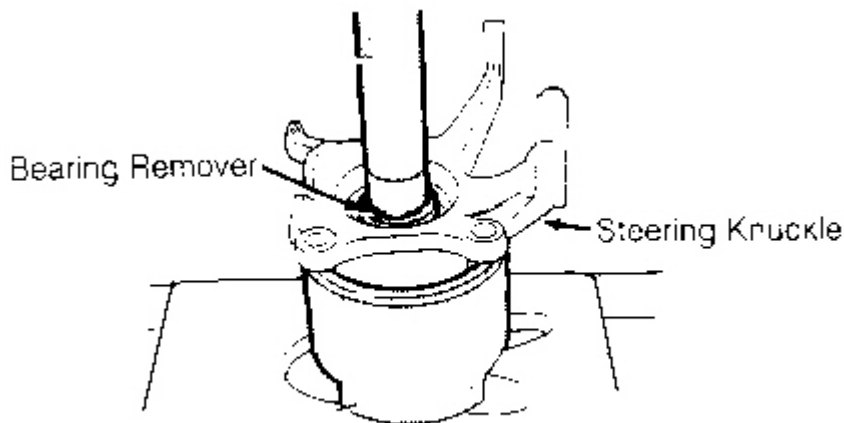

93A83519

Fig. 9: Pressing Wheel Bearing Out Of Steering Knuckle
 Courtesy of VOLKSWAGEN UNITED STATES, INC.

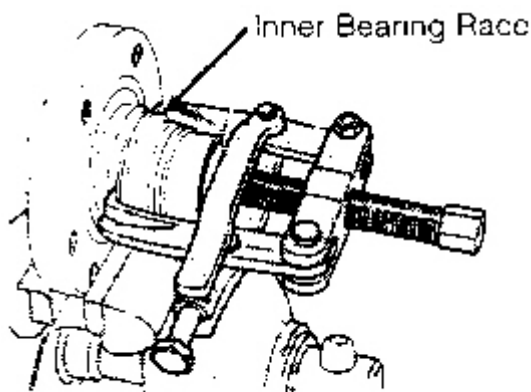

93D83520

Fig. 10: Removing Wheel Bearing Inner Race

Courtesy of VOLKSWAGEN UNITED STATES, INC.

NOTE: When installing hub, ensure press adapter contacts inner bearing race only.**Installation**

1. Press new wheel bearing race onto hub. Using Bearing Installer (3253/7), press new bearing into steering knuckle from outboard side. Using Hub Installer (3074), press new bearing into steering knuckle. See **Fig. 11**.
2. To complete installation, reverse removal procedure. Always replace self-locking axle shaft bolt. Tighten bolts and nuts to specification. See TORQUE SPECIFICATIONS. Check wheel alignment. See **WHEEL ALIGNMENT SPECIFICATIONS & PROCEDURES** article in WHEEL ALIGNMENT section.

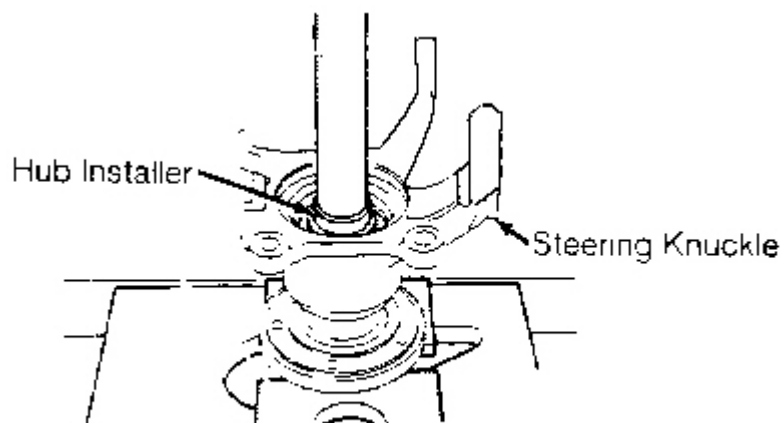

93E83521

Fig. 11: Pressing Wheel Hub Into Steering Knuckle**TORQUE SPECIFICATIONS****TORQUE SPECIFICATIONS**

| Application | Ft. Lbs. (N.m) |
|-------------------------------------|----------------|
| Axle Nut | 148 (200) |
| Axle Shaft-To-Transaxle Bolt | 41 (55) |
| Ball Joint Clamp Bolt | 37 (50) |
| Ball Joint-To-Steering Knuckle Bolt | 81 (110) |
| Brake Disc-To-Hub Bolt | 118 (160) |
| Caliper Bolt | 200 (265) |
| Caliper Pin Bolts | 18 (24) |
| Control Arm Pivot Bolt | |
| Lower | 118 (160) |
| Upper | 74 (116) |
| Tie Rod Castle Nut | 26 (35) |
| Torsion Bar Bolts | 118 (160) |

1996 Volkswagen EuroVan CV

SUSPENSION - FRONT

Wheel Lug Bolt

81 (110)